



**PARTS LIST  
OPERATING AND  
SERVICE MANUAL**



**LEGEND**

“P” SERIES  
BLOWERS

2” - 5” GEAR DIAMETER

**Models**

GAA \_ \_ P \_  
GAB \_ \_ P \_  
GAC \_ \_ P \_  
GAE \_ \_ P \_



Sunco Powder Systems, Inc.  
Blower Division  
Phone: (704) 545-3922  
[www.suncoblomers.com](http://www.suncoblomers.com)

**SB-7-621  
Version 05  
October, 2005**

**MAINTAIN BLOWER RELIABILITY AND PERFORMANCE  
WITH GENUINE GARDNER DENVER  
PARTS AND SUPPORT SERVICES**

Factory genuine parts, manufactured to design tolerances, are developed for optimum dependability --- specifically for your blower. Design and material innovations are born from years of experience with hundreds of different blower applications. When you specify factory genuine parts you are assured of receiving parts that incorporate the most current design advancements . . . manufactured in our state-of-the-art blower factory under exacting quality standards.

Your **AUTHORIZED DISTRIBUTOR** offers all the backup you require. A worldwide network of authorized distributors provides the finest product support in the blower industry.

Your **AUTHORIZED DISTRIBUTOR** can support your

blower investment with these services:

1. Trained parts technical representatives to assist you in selecting the correct replacement parts.
2. Complete inventory of new machines and new, genuine factory parts.
3. A full line of factory tested AEON™ PD blower lubricants specifically formulated for optimum performance in all blowers.
4. Authorized Distributor service technicians are factory-trained and skilled in blower maintenance and repair. They are ready to respond and assist you by providing fast, expert maintenance and repair services.

**INSTRUCTIONS FOR DETERMINING BLOWER CONFIGURATION**

1. Face the blower drive shaft.
2. In a **VERTICAL** configuration, air flow is horizontal.
3. In a **HORIZONTAL** configuration, air flow is vertical.
4. In a vertical configuration, a **BOTTOM HAND** exists when the drive shaft is below the horizontal center line of the blower. A **TOP HAND** exists when the drive shaft is above the horizontal center line of the blower.
5. In a horizontal configuration, a **RIGHT HAND** exists when the drive shaft is to the right of the vertical center line of the blower. A **LEFT HAND** exists when the drive shaft is to the left of the vertical center line of the blower.

**INSTRUCTIONS FOR ORDERING REPAIR PARTS**

For pricing and ordering information, contact your nearest **AUTHORIZED FACTORY DISTRIBUTOR**.

When ordering parts, specify Blower **MODEL** and **SERIAL NUMBER** (see nameplate on unit).

Rely upon the knowledge and experience of your **AUTHORIZED DISTRIBUTOR** and let them assist you in making the proper parts selection for your blower.

**For the location of your local authorized Gardner Denver blower distributor refer to the yellow pages of your phone directory, check the Web site at [www.gardnerdenver.com](http://www.gardnerdenver.com) or contact:**

**Gardner Denver  
1800 Gardner Expressway  
Quincy, IL 62305  
Phone: (217) 222-5400  
Fax: (217) 221-8780**

## GARDNER DENVER LUBRICANT ORDER INFORMATION

Re-order Part Numbers for Factory-Recommended Lubricants.

### Gear End

AEON PD Synthetic Lubricant or AEON PD-Food Grade Synthetic Lubricant

#### AEON PD Synthetic Lubricant

<u>Description</u>	<u>Part Number</u>
1 Quart	28G23
Case/12Quarts	28G24
5 Gallon Pail	28G25
55 Gallon Drum	28G28

#### AEON PD-Food Grade Synthetic Lubricant

<u>Description</u>	<u>Part Number</u>
1 Quart	28H97
Case/12Quarts	28H98
5 Gallon Pail	28H99
55 Gallon Drum	28H100

### Drive End

AEON PD Grease

<u>Description</u>	<u>Part Number</u>
Case/10 Tubes	28H283

**Call your local Sutorbilt Distributor to place your order for Gardner Denver lubricants. Your Authorized Gardner Denver Distributor is:**

---

---

---

## FOREWORD

Sutorbilt® blowers are the result of advanced engineering and skilled manufacturing. To be assured of receiving maximum service from this machine the owner must exercise care in its operation and maintenance. This book is written to give the operator and maintenance department essential information for day-to-day operation, maintenance and adjustment. Careful adherence to these instructions will result in economical operation and minimum downtime.

### **DANGER**

**Danger is used to indicate the presence of a hazard which will cause severe personal injury, death, or substantial property damage if the warning is ignored.**

### **WARNING**

**Warning is used to indicate the presence of a hazard which can cause severe personal injury, death, or substantial property damage if the warning is ignored.**

### **CAUTION**

**Caution is used to indicate the presence of a hazard which will or can cause minor personal injury or property damage if the warning is ignored.**

### **NOTICE**

**Notice is used to notify people of installation, operation or maintenance information which is important but not hazard-related.**

## SAFETY PRECAUTIONS

Safety is everybody's business and is based on your use of good common sense. All situations or circumstances cannot always be predicted and covered by established rules. Therefore, use your past experience, watch out for safety hazards and be cautious. Some general safety precautions are given below:

### **DANGER**

Failure to observe these notices could result in injury to or death of personnel.

- **Keep fingers and clothing away** from blower inlet and discharge ports, revolving belts, sheaves, drive coupling, etc.
- **Do not use the air discharge** from this unit for breathing - not suitable for human consumption.
- **Do not loosen or remove** the oil filler plug, drain plugs, covers, or break any connections, etc., in the blower air or oil system until the unit is shut down and the air pressure has been relieved.
- **Electrical shock** can and may be fatal.
- **Blower unit must be grounded** in accordance with the National Electrical Code. A ground jumper equal to the size of the equipment ground conductor must be used to connect the blower motor base to the unit base.
- **Open main disconnect switch**, tag and lockout before working on the control.
- **Disconnect the blower** unit from its power source, tag and lockout before working on the unit - the machine may be automatically controlled and may start at any time.

### **WARNING**

Failure to observe these notices could result in damage to equipment.

- **Stop the unit** if any repairs or adjustments on or around the blower are required.
- **Disconnect the blower** unit from its power source, tag and lockout before working on the unit - the machine may be automatically controlled and may start at any time.
- **Do not exceed** the rated maximum speed shown on the nameplate.
- **Do not operate unit** if safety devices are not operating properly. Check periodically. Never bypass safety devices.

## TABLE OF CONTENTS

### Page

Maintain Blower Reliability and Performance with Genuine Gardner Denver Parts and Support Services .....	i
Instructions for Ordering Repair Parts .....	i
Instructions for Determining Blower Configuration .....	i
Gardner Denver Lubricant Order Information .....	ii
Foreword .....	iii
Safety Precautions .....	iv
Index .....	vi
Sutorbilt Legend Series Blowers Matrix/Menu .....	vii
Introduction, Your Key To Trouble Free Service .....	1
Section 1, Equipment Check .....	2
Section 2, Installation .....	3
Section 3, Lubrication .....	7
Section 4, Operation .....	10
Section 5, Special Tools Required .....	13
Section 6, Disassembly Instructions .....	15
Section 7, Assembly Instructions .....	18
Section 8, Parts List .....	25
Warranty .....	Last Page

## INDEX

<p>AEON PD Food Grade Lubricant Part Numbers . . . 8</p> <p>AEON PD Lubricant Part Numbers . . . . . 8</p> <p>Air Filters and Filter-Silencers . . . . . 6</p> <p>ASSEMBLY INSTRUCTIONS, SECTION 7 . . . . . 18</p> <p>Blower Startup Checklist . . . . . 11</p> <p>Checklist, Blower Startup . . . . . 11</p> <p>DISASSEMBLY INSTRUCTIONS, SECTION 6 . . . 15</p> <p>Drive End Lubrication . . . . . 7</p> <p>Drive Installation . . . . . 4</p> <p>EQUIPMENT CHECK, SECTION 1 . . . . . 2</p> <p>Filter-Silencers, and Air Filters . . . . . 6</p> <p>Foreword . . . . . iii</p> <p>Foundation . . . . . 3</p> <p>Gear End Lubrication . . . . . 7</p> <p>Impeller End Clearances With Mechanical Seals, Setting . . . . . 23</p> <p>Impeller End Clearances, Setting . . . . . 22</p> <p>INSTALLATION, SECTION 2 . . . . . 3</p> <p>Installation, Location . . . . . 3</p> <p>Installation, Drive . . . . . 4</p> <p>Installing Timing Gears . . . . . 21</p> <p>Limitations, Operation . . . . . 10</p> <p>Location, Installation . . . . . 3</p> <p>Lubricant, Recommended . . . . . 8</p> <p>Lubricant Order Information . . . . . ii</p> <p>LUBRICATION, SECTION 3 . . . . . 7</p> <p>Lubrication Drive End . . . . . 7</p>	<p>Gear End . . . . . 7</p> <p>Lubrication Instructions . . . . . 8</p> <p>Filling Procedure . . . . . 8</p> <p>Matrix/Menu . . . . . vii</p> <p>Mounting Configurations . . . . . 3</p> <p>Mounting Feet, Repositioning . . . . . 3</p> <p>OPERATION, SECTION 4 . . . . . 10</p> <p>Outline Drawing and Parts List Model GAA . . . . . 25, 26</p> <p>Model GAB . . . . . 27, 28</p> <p>Model GAC . . . . . 29, 30</p> <p>Model GAE . . . . . 31, 32</p> <p>PARTS LIST, SECTION 8 . . . . . 25</p> <p>Piping . . . . . 4</p> <p>Protective Materials, Removing . . . . . 2</p> <p>Recommended Lubricant . . . . . 8</p> <p>Removing Protective Materials . . . . . 2</p> <p>Repair Parts, Ordering Instructions . . . . . i</p> <p>Safety Precautions . . . . . iv, 12</p> <p>Setting Impeller End Clearances . . . . . 22</p> <p>With Mechanical Seals . . . . . 23</p> <p>SPECIAL TOOLS REQUIRED, SECTION 5 . . . . . 13</p> <p>Startup Checklist, Blower . . . . . 11</p> <p>Storage . . . . . 2</p> <p>Timing Gears, Installing . . . . . 21</p> <p>Trouble Shooting . . . . . 12</p> <p>Warranty . . . . . Last Page</p> <p>YOUR KEY TO TROUBLE FREE SERVICE, INTRODUCTION . . . . . 1</p>
--	---

## LIST OF ILLUSTRATIONS

Figure 1	Blower Mounting Configuration . . . . .	3
Figure 2	Belt Drive Overhung Load Limitations . . . . .	5
Figure 3	Lubrication . . . . .	7
Figure 4	Approximate Oil Capacities . . . . .	8
Figure 5	AEON PD Synthetic Lubricant . . . . .	8
Figure 6	Lubrication Recommendation . . . . .	9
Figure 7	Maximum Operating Limitations . . . . .	10
Figure 8	Puller Plate . . . . .	13
Figure 9	Gear Driver . . . . .	13
Figure 10	Mechanical Seal Installation Tool . . . . .	14
Figure 11	Bearing Press Tool - Mechanical Seal Units . . . . .	14
Figure 25	Torque (Ft-Lbs) . . . . .	24

## SUTORBILT LEGEND SERIES BLOWERS MATRIX/MENU

NOTICE TO CUSTOMER - To find the construction options for your blower unit, FILL IN THE BALANCE OF LETTERS OR NUMBERS FROM YOUR UNIT NAMEPLATE

COLUMN NUMBER:

G	A				P	
1	2	3	4	5	6	7

FOLLOW THE LINE DOWN AND OVER FROM EACH SPACE THUS FILLED IN TO FIND THE APPROPRIATE CONSTRUCTION OPTION WITH WHICH YOUR MACHINE IS EQUIPPED.

COLUMN 1 - BASIC DESIGNATOR \_\_\_\_\_

COLUMN 2 - PRODUCT FAMILY \_\_\_\_\_

COLUMN 3 - GEAR DIAMETER \_\_\_\_\_

- |       |       |
|-------|-------|
| A. 2" | F. 6" |
| B. 3" | G. 7" |
| C. 4" | H. 8" |
| E. 5" |       |

COLUMN 4 - CASE LENGTH \_\_\_\_\_

- L - Low Pressure
- M - Medium Pressure
- H - High Pressure

COLUMN 5 - CONFIGURATION \_\_\_\_\_

- A. Vertical-Top Hand-Central Timed
- B. Vertical-Bottom Hand-Central Timed
- C. Horizontal-Left Hand-Central Timed
- D. Horizontal-Right Hand-Central Timed

COLUMN 6 - DESIGN VERSION \_\_\_\_\_

COLUMN 7 - ADDITIONAL DESCRIPTION \_\_\_\_\_

- A. Lip Seal
- B. Mechanical Seal



# **INTRODUCTION**

## **YOUR KEY TO TROUBLE FREE SERVICE**

---

Thank you for investing in Sutorbilt quality. The Sutorbilt reputation for rugged dependability has been earned by over 50 years of service in demanding, industrial operations where downtime cannot be tolerated and efficient blower performance is expected.

Your Sutorbilt blower is a precision engineered blower that has been carefully manufactured and thoroughly tested at the state-of-the-art Gardner Denver Blower Factory in Sedalia, Missouri.

As with other precision machinery, there are several relatively simple installation, operation and maintenance

procedures that you must observe to assure optimum blower performance. There is no guesswork in the manufacture of your highly advanced Sutorbilt blower and there must be none in preparing the blower to get the job done in the field.

The purpose of this manual is to help you properly install, operate and maintain your Sutorbilt blower. It is essential that you review all sections of this manual in preparation for installing your blower. Follow the instructions carefully and you will be rewarded with trouble-free Sutorbilt service . . . year in and year out.

# SECTION 1 EQUIPMENT CHECK

Before uncrating, check the packing slip carefully to be sure all the parts have been received. All accessories are listed as separate items on the packing slip, and small important accessories such as relief valves can be overlooked or lost. After every item on the packing slip has been checked off, uncrate carefully.

## NOTICE

**Register a claim with the carrier for lost or damaged equipment.**

## WARNING

**Customers are cautioned to provide adequate protection, warning and safety equipment necessary to protect personnel against hazards involved in installation and operation of this equipment in the system or facility.**

## STORAGE

Your Sutorbilt Blower was packaged at the factory with adequate protection to permit normal storage for up to six (6) months.

If the unit is to be stored under adverse conditions or for extended periods of time, the following additional measures should be taken to prevent damage.

1. Store the blower in a clean, dry, heated (if possible) area.
2. Make certain inlet and discharge air ports are tightly covered to prevent foreign material from entering the air box.
3. All exposed, non-painted surfaces should be protected against rust and corrosion.
4. Provide adequate protection to avoid accidental mechanical damage.
5. In high humidity or corrosive environments, additional measures may be required to prevent rusting of the blower internal surfaces.
6. To prevent rusting of gears, bearings, etc., the oil reservoirs may be filled with normal operating oil.

## CAUTION

**Before running the blower, drain the oil and replace to the proper operating level with clean, fresh lubricant.**

7. Rotate the blower shaft (10 to 25 turns) weekly during storage. Inspect the blower shaft (near the shaft seal area) monthly and spray with rust inhibitor if needed.
8. For long term storage (over six (6) months), contact Sutorbilt Customer Service for recommendations.

## REMOVING PROTECTIVE MATERIALS

The shaft extension is protected with rust inhibitor which can be removed with any standard solvent.

## CAUTION

**Follow the safety directions of the solvent manufacturer.**

Blower inlet and outlet are temporarily capped to keep out dirt and other contaminants during shipment. These covers must be removed before start-up.

The internal surfaces of all Sutorbilt units are mist sprayed with a rust preventative to protect the machine during shipment. Remove this film upon initial startup, using any commercial safety solvent. Position the blower so that the inlet and discharge connections are in the vertical position (vertical airflow). On vertically mounted units, it will be necessary to lay the unit on its side supporting the ends of the unit so as not to restrict the port on the bottom side. Place a shallow pan on the under side of the unit. With the blower disconnected from power, spray the solvent in the top port, rotating the impellers by spinning the shaft manually. Continue this procedure until the unit is visibly clean.

## WARNING

**Rotating components will cause severe injury in case of personal contact. Keep hands and loose clothing away from blower inlet and discharge ports.**

## SECTION 2 INSTALLATION

### LOCATION

If possible, install the blower in a well lit, clean, dry place with plenty of room for inspection and maintenance.

### FOUNDATIONS

For permanent installations we recommend concrete foundations be provided, and the equipment should be grouted to the concrete. It is necessary that a suitable base be used, such as a steel combination base under blower and motor, or a separate sole plate under each. Before grouting, equipment must be leveled, free of all strains, and anchored so no movement will occur during setting of grout. After grout has completely hardened, a recheck is necessary to compensate for shrinkage, etc. If required, add shims under blower feet after final tightening of foundation anchor bolts to remove strain from the blower housing.

Where jack screws or wedges are used during grouting, they must be backed off or removed before final tightening of anchor bolts.

Where a concrete foundation is not feasible, care must be taken to insure that equipment is firmly anchored to adequate structural members, restricting movement and vibration.

### MOUNTING CONFIGURATIONS

The blower flex-mount design enables horizontal and vertical mounting configurations with top or bottom hand, right or left hand shaft positioning. The units are center timed allowing rotation in either direction (refer to FIGURE 1). If converting a blower from vertical to horizontal, or horizontal to vertical mounting configuration, additional mounting feet will be required.

### REPOSITIONING THE MOUNTING FEET:

1. Position the mounting feet to the desired location and snug the capscrew.
2. Place the blower on its feet on a flat surface.
3. Loosen mounting feet capscrews and level unit up. The bench or blower base flatness should be within .002 of an inch.

### NOTICE

**If the unit is not flat within .002 of an inch, it will be necessary to shim the blower feet at installation.**

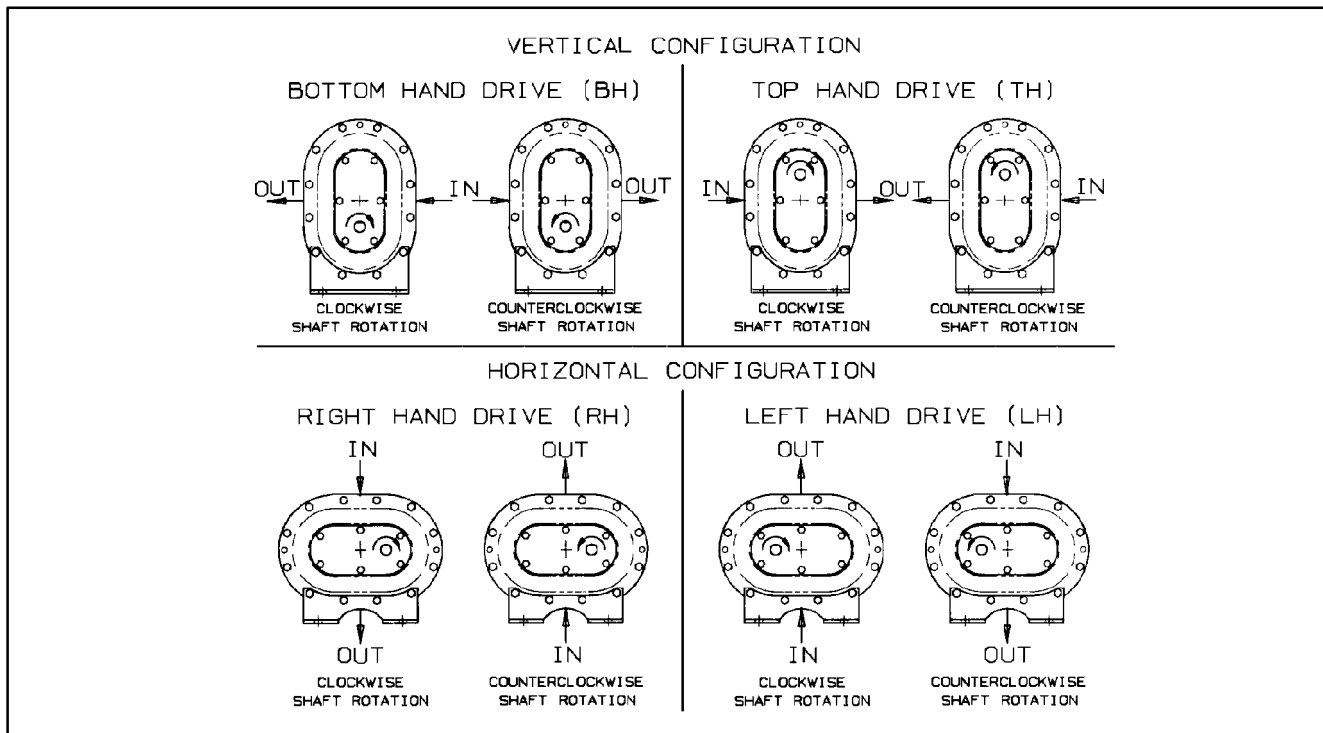

FIGURE 1 - BLOWER MOUNTING CONFIGURATIONS

- Secure the mounting feet capscrews to the torque value in FIGURE 25, page 24.

## NOTICE

**When changing mounting configuration, it may be necessary to reposition vent plug (B), and drain plug (A). Refer to FIGURE 3, page 7, for correct location.**

### DRIVE INSTALLATION

When selecting a V-belt drive, check to be sure the shaft overhung load limitation is not exceeded. Refer to FIGURE 2, page 5, for overhung load calculations and limitations.

Belt drives must be carefully aligned. Motor and blower pulleys must be parallel to each other and in the same plane within 1/32 inch. Belt tension should be carefully adjusted to the belt manufacturer's recommendation using a belt tension gauge. Check tension frequently during the first day of operation.

## WARNING

**Overtightening belts leads to heavy bearing loads and premature failure.**

On the direct connected units, alignment and lubrication of couplings to specifications of the coupling manufacturer is very important. When mounted drives are supplied from the factory, proper alignment has been established before shipment. However, during shipping, handling and installation, it is likely that the alignment has been disturbed and final adjustment must be made before startup.

## WARNING

**Exceeding overhung load limitations leads to unwarrantable premature bearing failure and shaft breakage.**

The location of the sheave on the blower shaft greatly affects the stress in the shaft. The optimum blower sheave positioning is as close as possible to the blower drive cover, not to exceed dimension "C" in Drive Shaft Illustration, FIGURE 2, page 5.

The calculated shaft moment must not exceed the maximum allowable moment listed in Maximum Allowable Moment Chart, FIGURE 2, page 5. If the calculated shaft moment exceeds the maximum allowable moment:

- Increase Sheave Diameters to Reduce Belt Pull
- Use Jackshaft Drive
- Use Direct Coupled or Gearbox Drive

To calculate shaft moment for a given V-Belt Drive Arrangement:

1. Use the formula for Calculation of Belt Pull, FIGURE 2, page 5, to calculate belt pull. Refer to Arc of Contact Factor Chart, FIGURE 2, page 5.
2. Insert the calculated belt pull into the formula for Calculation of Shaft Moment, FIGURE 2, page 5, to arrive at the calculated shaft moment.

### PIPING

Inlet and discharge connections on all blowers are large enough to handle maximum volume with minimum friction loss. Reducing the pipe diameter on either inlet or discharge will only create additional line loss and increase the overall pressure differential.

Excessive weight of piping and fittings will cause internal misalignment and premature wear. Never allow the blower to carry the weight of the pipe. If possible, a spool or sleeve-type expansion joint should be installed between the unit and the piping. Where a flexible connection is not practical, the weight of the rigid connection must be separately supported.

All system piping must be cleaned internally before connecting to the blower.

## WARNING

**Sutorbilt blowers are shipped dry from the factory. Do not attempt to operate the blower before following proper lubrication instructions. Permanent damage to the gears, bearings and seals will occur.**

Gear Diameter (Inches)	Dimensions (Inches)			Maximum Allowable Moment (LB-IN)
	A	B	C (Max)	
2	2.76	.80	.38	146
3	2.88	.85	.38	385
4	3.49	1.10	.38	490
5	3.90	1.40	.38	1245

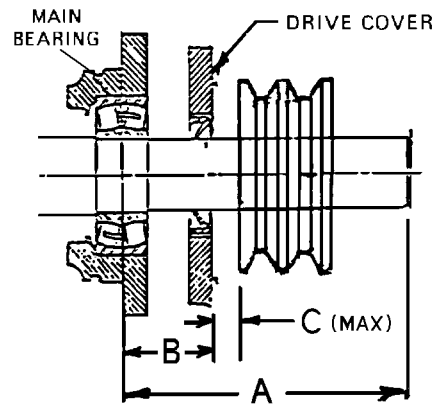

**MAXIMUM ALLOWABLE MOMENT**

**DRIVE SHAFT ILLUSTRATION**

Z	Ac	Z	Ac	Z	Ac	Z	Ac	Z	Ac	Z	Ac
0.000	1.000	0.250	0.966	0.500	0.926	0.750	0.879	1.000	0.823	1.250	0.751
0.025	0.997	0.275	0.962	0.525	0.922	0.775	0.874	1.025	0.816	1.275	0.742
0.050	0.994	0.300	0.958	0.550	0.917	0.800	0.869	1.050	0.810	1.300	0.734
0.075	0.990	0.325	0.954	0.575	0.913	0.825	0.864	1.075	0.803	1.325	0.725
0.100	0.987	0.350	0.951	0.600	0.908	0.850	0.858	1.100	0.796	1.350	0.716
0.125	0.983	0.375	0.947	0.625	0.904	0.875	0.852	1.125	0.789	1.375	0.706
0.150	0.980	0.400	0.943	0.650	0.899	0.900	0.847	1.150	0.782	1.400	0.697
0.175	0.977	0.425	0.939	0.675	0.894	0.925	0.841	1.175	0.774	1.425	0.687
0.200	0.973	0.450	0.935	0.700	0.889	0.950	0.835	1.200	0.767		
0.225	0.969	0.475	0.930	0.725	0.884	0.975	0.829	1.225	0.759		

**ARC OF CONTACT FACTORS**

$$\text{Belt Pull} = \left[ \frac{2.5 - A_c}{A_c} \right] \left[ \frac{125954 \times H_p \times S.F.}{D \times \text{RPM}} \right]$$

- Key:
- A<sub>c</sub> = Arc of Contact Factor (Refer to Arc of Contact Factors Chart above)
  - H<sub>p</sub> = Blower Horsepower for Operating Conditions
  - S.F. = Actual Drive Service Factor
  - D = Blower Sheave Pitch Diameter in Inches
  - RPM = Blower Sheave Speed
  - Z =  $\left[ \frac{\text{Large Sheave Pitch Diameter (in)} - \text{Small Sheave Pitch Diameter (in)}}{\text{Sheave Center Distance (in)}} \right]$

**CALCULATION OF BELT PULL**

$$\text{Shaft Moment (LB-IN)} = \text{Belt Pull} \times \left[ B + C + \left( \frac{\text{Sheave Width}}{2} \right) \right]$$

**CALCULATION OF SHAFT MOMENT**

**FIGURE 2 - BELT DRIVE OVERHUNG LOAD CALCULATIONS**

## AIR FILTERS AND FILTER SILENCERS

 **WARNING**

**Servicing the air filters is one of the most important maintenance operations to be performed to insure long blower life.**

Servicing frequency of filter elements is not time predictable. A differential pressure indicator, with a continuous gauge reading, should be installed across the inlet filter. It will tell how much of the service life of the filter element has been used. It will also eliminate both premature filter servicing and premature blower failure

due to a plugged filter when the filter pressure drop is used to establish maintenance points.

In all cases refer to the filter manufacturer's service instructions. Due to the many types of filters, it is not practical to give specific instructions covering all models.

**NOTICE**

**No matter what type of filter is used, always make sure all seats, gaskets, clamps and hose connections on the filter and inlet line are absolutely air tight. Each time the filter is serviced, inspect interior of the blower for dirt.**

## SECTION 3 LUBRICATION

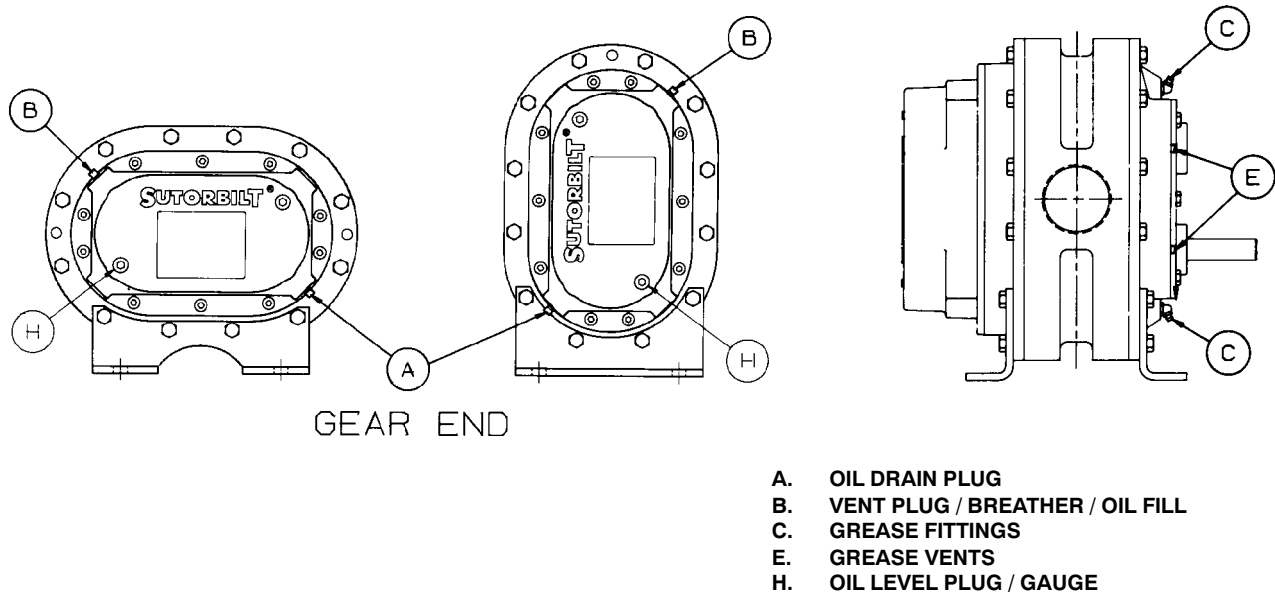

FIGURE 3 - LUBRICATION

### DRIVE END LUBRICATION

Drive end bearings are grease lubricated at the factory with Lithium Complex based grease. **For relubrication, use Gardner Denver AEON PD Grease, Part Number 28H283.** AEON PD Grease is a high temperature, high performance grease that is formulated with antiwear additives to provide superior service under the severe operating conditions of positive displacement blowers. It contains rust inhibitors which provide excellent protection against rust and corrosion.

If you choose not to use AEON PD Grease, select a compatible base grease. The grease should be NLGI Grade 2 EP, contain rust inhibitors, and be suitable for blower discharge temperatures up to 350° F (177° C). Completely clean or purge the factory-filled grease from the blower. **Do not mix different types of grease as they may not be compatible. Substitutions may cause early bearing failure.**

Re-grease bearings every 500 hours of operation. Lubricate each bearing through the grease fittings

located at C in FIGURE 3 (2 places). When re-greasing, the old grease will be forced out of the vents (E in FIGURE 3). To prevent damage to seals, these vents must be open at all times.

### WARNING

**Do not over-grease bearings as this could cause premature bearing failure.**

### GEAR END LUBRICATION

At the gear end, the timing gear teeth are lubricated by being partially submerged in oil. The gear teeth serve as oil slingers for gear end bearings.

Approximate oil sump capacities are listed in FIGURE 4, page 8.

**RECOMMENDED LUBRICANT**

Gear Diameter	Vertical	Horizontal
2"	1/4 PT.	1/2 PT.
3"	1/3 PT.	2/3 PT.
4"	3/4 PT.	1 PT.
5"	1 PT.	2-1/4 PT.

**FIGURE 4 - APPROXIMATE OIL CAPACITIES**

The factory recommended lubricant is **AEON PD Synthetic Lubricant**. AEON PD is formulated especially for positive displacement blowers to provide maximum protection at any temperature. One filling of AEON PD will last a minimum of 4 times longer than a premium mineral oil, depending on actual operating conditions. AEON PD contains a special additive package designed for greater rust and corrosion protection.

<b>AEON PD Lubricant</b>	
<b>Description</b>	<b>Part Number</b>
1 Quart	28G23
Case/12Quarts	28G24
5 Gallon Pail	28G25
55 Gallon Drum	28G28
<b>AEON PD Food Grade Lubricant</b>	
<b>Description</b>	<b>Part Number</b>
1 Quart	28H97
Case/12Quarts	28H98
5 Gallon Pail	28H99
55 Gallon Drum	28H100

**FIGURE 5 - AEON PD SYNTHETIC LUBRICANT**

**NOTICE**

**Machines are shipped without oil in the sump. Do not operate before adding lubricant.**

**LUBRICATION INSTRUCTIONS**

**Filling Procedure (For 2" and 3" sizes)**

Refer to FIGURE 3, page 7. Remove the oil level plug (H) and the square head vented oil fill plug (B) from the gear cover. Add oil to the gear case until oil drips out of the oil level hole (H). Secure plugs in their correct location.

**Filling procedure (For 4" and 5" sizes)**

Refer to FIGURE 3, page 7. Remove the breather (B) from the gear cover. Add oil to the gear case until oil reaches the center of the oil level gauge (H). Secure breather (B) in the gear cover.

Add fresh oil as required to maintain proper level. The oil level should be at the middle of the sight glass when the machine is not operating.

 **WARNING**

**Do not overfill as this will tend to cause excessive heating of the gears and may damage the unit.**

AEON PD Synthetic Lubricant should be drained after 6000 hours of operation. Re-fill with fresh AEON PD oil. If mineral oil is used, perform the above oil-change maintenance every 1500 hours. Recommended service intervals are for normal blower operating conditions. Severe operating conditions may warrant more frequent oil changes. Laboratory analysis of lubricant should be used to help determine the optimum oil change interval.

For best performance and equipment protection, use AEON PD Synthetic Lubricant, which has been specifically formulated for positive displacement blowers. If you choose not to use AEON PD Synthetic Blower Lubricant, select an oil with rust and oxidation inhibitors, anti-foam additives, and the viscosities listed in FIGURE 6, page 9. Do not use an oil that contains EP additives.

**NOTICE**

**Flush the oil whenever a change is made from one type of oil to another.**

Drain the current lubricant as thoroughly as possible. Refill with the new lubricant. Fill to normal level of the blower, which is at the middle of the sight glass when the machine is not operating. Run the blower for one hour. Shut off the blower and drain the lubricant completely. Refill the blower again with the new lubricant.



Blower Discharge Temperature	Ambient Temperature			
	Less than 10° F *	10° F to 32° F **	32° F to 90° F	Greater than 90° F
Less than 32° F (0° C)	ISO 100 ‡	ISO 100 ‡		
32° F to 100° F (0° C to 38° C)	ISO 100 ‡	ISO 100 ‡	ISO 150 ‡	
100° F to 225° F (38° C to 105° C)	ISO 100 ‡	ISO 100 ‡	ISO 150 ‡	ISO 220 ‡
225° F to 300° F (105° C to 149° C)	ISO 150 ‡	ISO 150 ‡	ISO 220 ‡	ISO 220 ‡
Greater than 300° F (149° C)			*** ‡	*** ‡

\* For ambient temperatures less than 10° F, but not less than -20° F, the use of oil sump heaters, heated enclosures or synthetic lubricant is required.

\*\* For ambient temperatures 10° F to 32° F, the use of oil sump heaters, heated enclosures or synthetic lubricant is recommended.

\*\*\* The lubricant viscosity must be 70 SUS minimum at the lubricant operating temperature.

The pour point of the lubricant should be at least 5° to 10° F below the minimum expected ambient temperature.

For continuous operation, where the lubricant temperature exceeds 200° F, synthetic lubricant is recommended.

‡ The recommended operating range for AEON PD Synthetic Lubricant.

**FIGURE 6 - LUBRICATION RECOMMENDATION**

## SECTION 4 OPERATION

Future operating problems can be avoided if proper precautions are observed when the equipment is first put into service.

Before starting under power, the blower should be turned over by hand to make certain there is no binding, or internal contact.

Each size blower has limits on pressure differential, running speed, and discharge temperature which must not be exceeded. These limits are shown in the following tabulation.

### **WARNING**

**Operating beyond the specified operating limitations will result in damage to the unit.**

It is important that the pressures and temperatures are measured directly at the ports of the blower to avoid error that may be caused by intervening pipe runs, fittings, etc.

Relief valves should be used to protect against exces-

sive pressure or vacuum conditions. These valves should be tested at initial startup to be sure they are adjusted to relieve at or below the maximum pressure differential rating of the blower.

### **NOTICE**

**Relief valves should be placed as close as possible to the blower inlet or discharge.**

In some instances, pressure may be relieved at a lower point than the blower maximum in order to protect the motor or the equipment served by the blower.

Discharge temperature switches are recommended to protect against excessive inlet restriction or inlet temperatures. Check valves in the discharge line on pressure blowers and in the inlet line on vacuum blowers are recommended to protect the blower from motoring backwards when shut down under load.

### **LIMITATIONS**

For information regarding limitations, refer to FIGURE 7, below.

<b>MAXIMUM OPERATING LIMITATIONS</b>					
SIZE	RPM	PRESSURE PSI	VACUUM IN HG	DISCHARGE TEMPERATURE °F	
2LP	5275	7	14	285	
2MP	5275	12	15	315	
3LP	3600	7	14	260	
3MP	3600	12	15	280	
3HP	3600	15	16	320	
4LP	3600	7	14	260	
4MP	3600	10	16	285	
4HP	3600	15	16	310	
5LP	2850	7	14	260	
5MP	2850	13	16	280	
5HP	2850	15	16	300	

**DO NOT EXCEED THESE LIMITS**

### **NOTICE**

**Blower speed, line losses, elevation, and increased inlet temperatures will affect the maximum operating limitations.**

FIGURE 7 - MAXIMUM OPERATING LIMITATIONS

## BLOWER STARTUP CHECKLIST

This startup procedure should be followed during the initial installation and after any shutdown periods or after the blower has been worked on or moved to a new location. It is suggested that the steps be followed in sequence and checked off ( ✓ ) in the boxes provided.

1. Check the unit and all piping for foreign material and clean if required.
2. Check the flatness of the feet and the alignment of the drive. Feet that are bolted down in a bind can cause case distortion and internal rubbing. Misaligned V-drives can cause the impellers to rub against the headplates and cause a reduction in the volumetric efficiency of the unit. Misaligned couplings can ruin bearings.
3. If blower is V-belt driven, check the belt tension and alignment. Over-tensioned belts create heavy bearing loads which leads to premature failure.
4. Be sure adequate drive guards are in place to protect the operator from severe personal injury from incidental contact.
5. Check the unit for proper lubrication. Proper oil level cannot be overemphasized. Too little oil will ruin bearings and gears. Too much oil will cause overheating and can ruin gears and cause other damage. Insure drive end bearings are greased.
6. With motor locked out, turn the drive shaft by hand to be certain the impellers do not bind.
7. "Jog" the unit with the motor a few times to check rotation and to be certain it turns freely and smoothly.
8. The internal surfaces of all Sutorbilt units are mist sprayed with a rust preventive to protect the machine during the shipping and installation period. This film should be removed prior to start-up.
9. Start the unit and operate 15 minutes at no load. During this time, check for hot spots and other indications of interference.
10. Apply the load and observe the operation of the unit for one hour. Check frequently during the first day of operation.
11. If malfunctions occur, do not continue to operate. Problems such as knocking impellers can cause serious damage if the unit is operated without correction.

**SAFETY PRECAUTIONS**

1. Do not operate blower with open inlet or outlet port.
2. Do not exceed specified vacuum or pressure limitations.
3. Do not operate above or below recommended blower speed range.
4. Blower is not to be used where non-sparking equipment is specified.
5. Do not operate without belt guard or coupling shield.

 <b>WARNING</b>
<b>Do not exceed sheave or coupling manufacturers' rim speed limit.</b>

6. The blower and blower discharge piping may be extremely hot and can cause skin burns on contact.

**TROUBLE SHOOTING**

No matter how well the equipment is designed and manufactured, there may be times when servicing will be required due to normal wear, the need for adjustment, or various external causes. Whenever equip-

ment needs attention, the operator or repairman should be able to locate the cause and correct the trouble quickly. The Trouble Shooting Chart below is provided to assist the mechanic in those respects.

PROBLEM	POSSIBLE CAUSES	SOLUTION
Knocking	<ol style="list-style-type: none"> <li>1. Unit out of time.</li> <li>2. Distortion due to improper mounting or pipe strains.</li> <li>3. Excessive pressure differential.</li> <li>4. Worn gears.</li> <li>5. Worn bearings.</li> </ol>	<ol style="list-style-type: none"> <li>1. Retime impellers.</li> <li>2. Check mounting alignment and relieve pipe strains.</li> <li>3. Reduce to manufacturer's recommended pressure. Examine relief valve, re-set if necessary.</li> <li>4. Replace timing gears.</li> <li>5. Replace bearings.</li> </ol>
Excessive blower temperature.	<ol style="list-style-type: none"> <li>1. Too much oil in gear case.</li> <li>2. Too low operating speed.</li> <li>3. Dirty air Filter</li> <li>4. Clogged filter or muffler.</li> <li>5. Excessive pressure differential.</li> <li>6. Worn impeller clearances.</li> <li>7. Internal contact.</li> </ol>	<ol style="list-style-type: none"> <li>1. Reduce oil level.</li> <li>2. Increase blower speed.</li> <li>3. Clean or replace air filter.</li> <li>4. Remove cause of obstruction.</li> <li>5. Reduce pressure differential across the blower.</li> <li>6. Replace impeller.</li> <li>7. Correct clearances.</li> </ol>
Impeller end or tip drag.	<ol style="list-style-type: none"> <li>1. Insufficient assembled clearances.</li> <li>2. Case or frame distortion.</li> <li>3. Excessive operating pressure.</li> <li>4. Excessive operating temperature.</li> </ol>	<ol style="list-style-type: none"> <li>1. Correct clearances.</li> <li>2. Check mounting and pipe strain.</li> <li>3. Remove cause.</li> <li>4. Remove cause.</li> </ol>
Lack of volume.	<ol style="list-style-type: none"> <li>1. Slipping belts.</li> <li>2. Worn clearances.</li> <li>3. Dirty air Filter</li> </ol>	<ol style="list-style-type: none"> <li>1. Tighten belts.</li> <li>2. Re-establish proper clearances.</li> <li>3. Clean or replace air filter.</li> </ol>
Excessive bearing or gear wear.	<ol style="list-style-type: none"> <li>1. Improper lubrication.</li> </ol>	<ol style="list-style-type: none"> <li>1. Correct lubrication level. Replace dirty oil.</li> </ol>
Loss of oil.	<ol style="list-style-type: none"> <li>1. Headplate, gear case or drive cover vents plugged.</li> <li>2. Worn seal.</li> </ol>	<ol style="list-style-type: none"> <li>1. Clean vents.</li> <li>2. Replace seals.</li> </ol>

**SECTION 5  
SPECIAL TOOLS REQUIRED**

---

ORDER SPECIAL TOOLS BY PART NUMBER. SEE PAGE i FOR ORDERING INSTRUCTIONS.

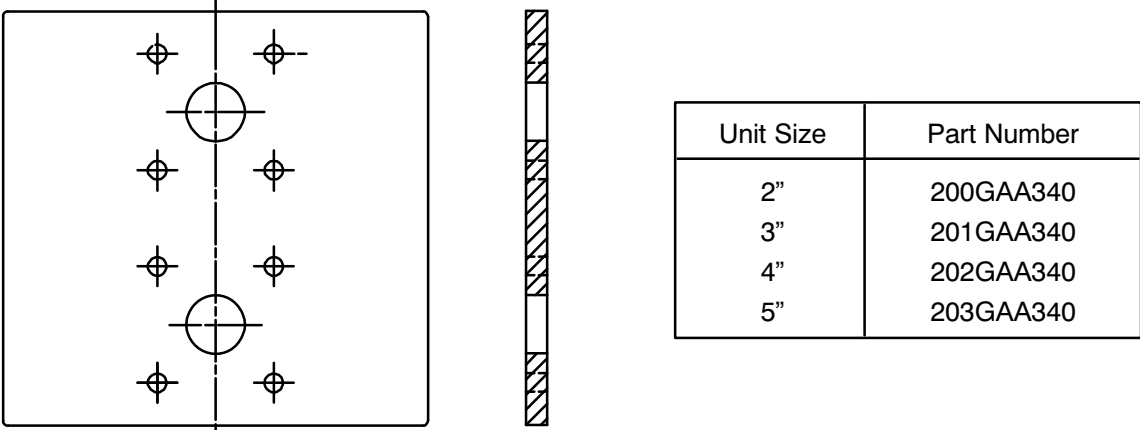

FIGURE 8 - PULLER PLATE

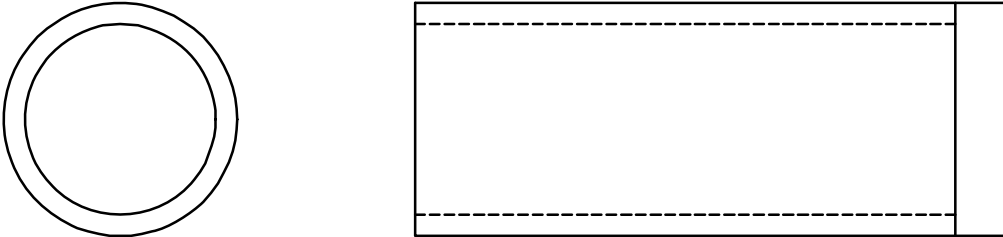
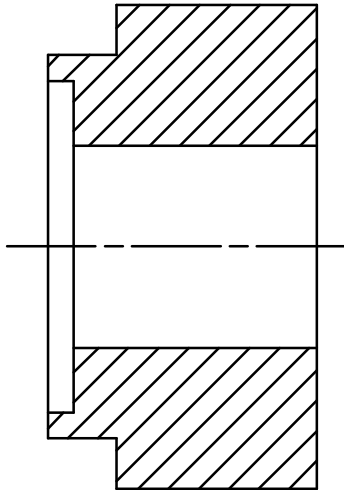
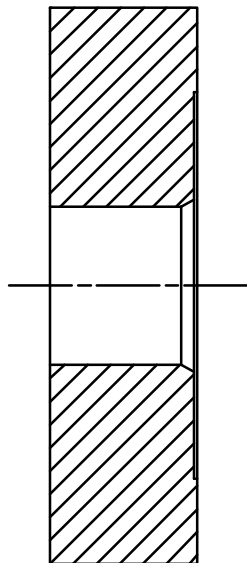

FIGURE 9 - GEAR DRIVER - 208GAA074



Unit Size	Part Number
2"	204GAA074
3"	205GAA074
4"	206GAA074
5"	207GAA074

FIGURE 10 - MECHANICAL SEAL INSTALLATION TOOL



Unit Size	Part Number
2"	200GAA074
3"	201GAA074
4"	202GAA074
5"	203GAA074

FIGURE 11 - BEARING PRESS TOOL - MECHANICAL SEAL UNITS

## SECTION 6 DISASSEMBLY INSTRUCTIONS

### NOTICE

Numbers in parentheses ( ) refer to key numbers in assembly drawings on pages 25, 27, 29 and 31.

1. Drain oil from gear case by removing drain plug (4).
2. Remove the socket head bolts (5) from the gear cover (3).
3. Remove the gear cover from the gear headplate.

### NOTICE

The cover and gear headplate gasket tends to bond tightly to both surfaces. After socket head bolt removal, it is sometimes necessary to take a ball peen hammer and a blunt chisel and drive off the cover.

IMPORTANT:

MARK ALL PARTS WITH A CENTER PUNCH SO

THEY CAN BE REASSEMBLED IN THE SAME POSITION (IMPELLERS, HEADPLATES, AND GEARS).

4. If the timing gears appear undamaged, the gear backlash must be checked to see if the gears can be salvaged.
  - A. Mount a magnetic base dial indicator on the gear headplate (see FIGURE 12).
  - B. Lock one impeller stationary by wedging a feeler gauge between the impeller and the headplate.
  - C. The tip of the indicator should be placed at the center of the contact surface on a tooth of the gear on the free shaft.
  - D. Rock the impeller back and forth by hand and read the total rotational movement to the nearest .0005 inches. Do this at four gear mesh positions 90 degrees apart.
  - E. Permissible gear backlash is shown below.

GEAR DIA.	GEAR BACKLASH
2"	.0015 - .0025
3"	.0015 - .0025
4"	.0015 - .0025
5"	.002 - .003

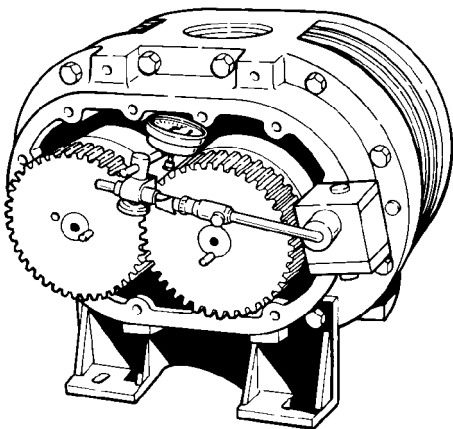

FIGURE 12

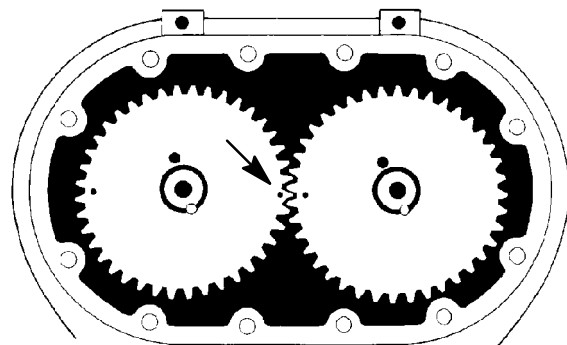

FIGURE 13

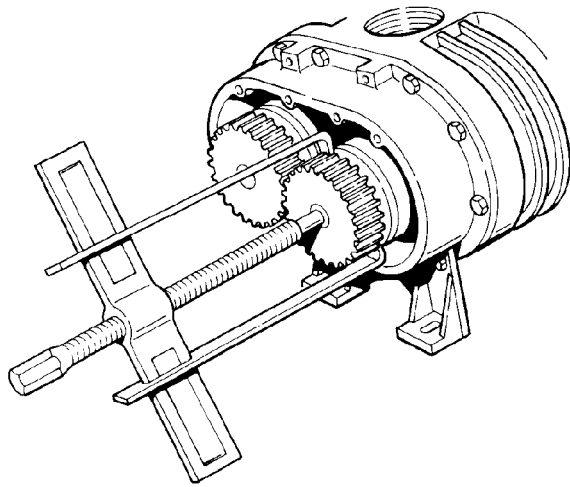

FIGURE 14

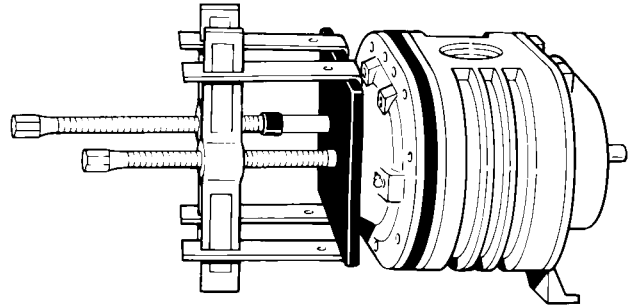

FIGURE 15

### NOTICE

**If backlash is above the specified limit, the gears are not necessarily unusable. Excessive play could be caused by worn bearings.**

5. If timing gears appear to be reusable, matchmark timing gear toothmesh by making small punch marks on the ends of meshing gear teeth with a pin punch and hammer (see FIGURE 13, page 15). The impeller tip to valley (throat) and the case to headplates should also be match marked to facilitate blower reassembly.
6. Using a gear puller, remove timing gears. The taper pin should back out with the gear as the gear is being removed (see FIGURE 14). Use caution not to damage gear teeth with puller if gears are to be used again.

### NOTICE

**Blowers with mechanical seals have two wavy washers (28) located between the bearings and the cover on the drive end.**

7. Remove the socket head cap screws (30) from the drive end bearing cover (29) and remove the cover. Drive shaft oil seal (31) should come free when cover is removed.

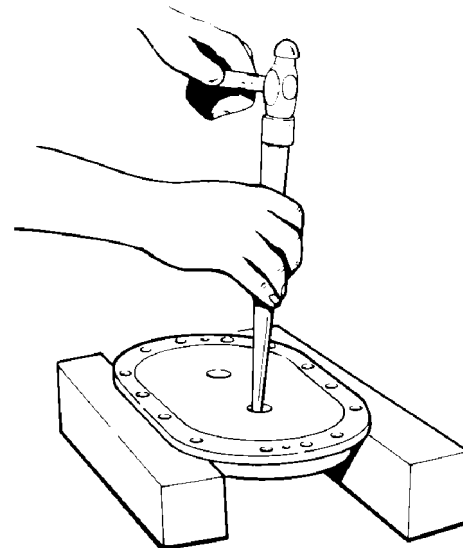

FIGURE 16

8. Remove mounting foot (17) from the drive headplate (24) by removing the capscrews (16).
9. Remove the capscrews (21) which secure the drive headplate (24) to the impeller case (22).
10. Using the puller plate shown on page 13, bolt to the drive headplate using the tapped holes used to secure the drive cover.
11. Install a gear puller to each shaft and attach puller arms to the plate. Turn each puller only half a revolution at a time keeping the advance of the shafts as uniform as possible (see FIGURE 15). After the headplate has been removed, detach the puller plate.



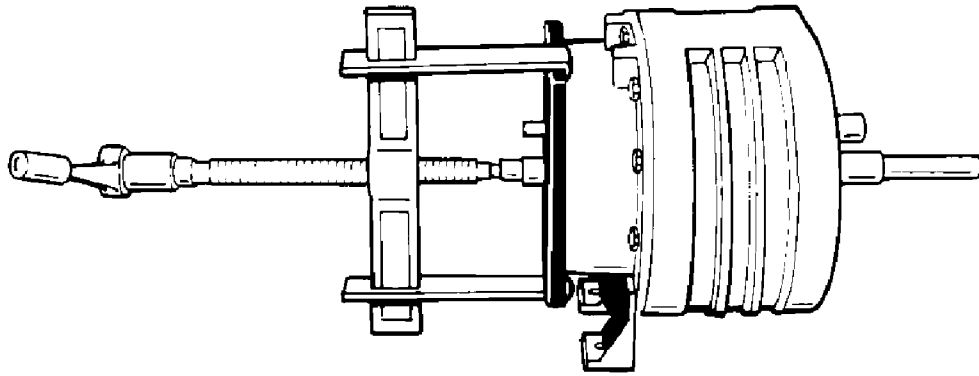

FIGURE 17

12. Remove the two drive end bearings (15) from the drive headplate (24) using a ball peen hammer and punch (see FIGURE 16, page 16).



### CAUTION

**Exercise care not to damage the headplate bearing bores when removing bearings.**

13. The grease seals can now be driven out of the drive headplate with hammer and punch (see FIGURE 16, page 16). Discard the seals as they will not be reused. Replace grease seals each time the headplate is removed.

### NOTICE

**Seals and bearings should be replaced during overhaul as a matter of service policy.**

14. Remove the four cap screws (10), which fasten the bearing retainers (12) to the gear headplate.
15. Attach puller plate to the gear headplate using the tapped holes used to secure the bearing retainers.
16. Install a gear puller to one of the shafts and attach puller arms to the plate (see FIGURE 17).
17. Remove mounting foot (17) from the gear headplate by removing 4 capscrews (16).
18. Push the impeller shaft through the gear headplate and remove the impeller assembly (23) (see FIGURE 17). Remove the other impeller assembly following the same procedure.
19. Remove the cap screws (21) securing the gear headplate to the impeller case. Located near each dowel pin on the headplate is a threaded hole. Insert a 5/16-18 UNC capscrew into each of the threaded holes. Tighten the screws evenly until the headplate separates from the impeller case.
20. Remove the two gear end bearings (14) from the gear headplate (18) as done in step 12.
21. Remove the oil seals (15) from gear headplate (19) as done in step 13.

## SECTION 7 ASSEMBLY INSTRUCTIONS

### NOTICE

Numbers in parentheses ( ) refer to key numbers in assembly drawings on pages 25, 27, 29 and 31.

1. Make sure all metallic parts are clean and free of any nicks or burrs.
2. Lubricate the outside diameter of the lip seal (15) with a light oil or grease. Install seals in both the drive headplate (24) and gear headplate (18). The seal lip should always face towards the bearing or lubricant. New seals should be installed each time the headplate is removed.

### NOTICE

Make sure seals are fully seated. Use extreme care when installing.

### MECHANICAL SEALS ONLY

- A. Lightly coat the headplate bores with assembly lubricant.
- B. Refer to FIGURE 18. Install mechanical seal (A) into the headplate bore (C) using a press and the correct driver shown on page 14. Drive the seal securely on to its seat.



### CAUTION

Use extreme care when installing seals in the headplate bores. Do not attempt to install the mechanical seals without the use of a press. Blows from a hammer or mallet can damage the fragile seal surface. Too much force can crush the seal casing. Make certain the seal is properly seated and undamaged before proceeding.

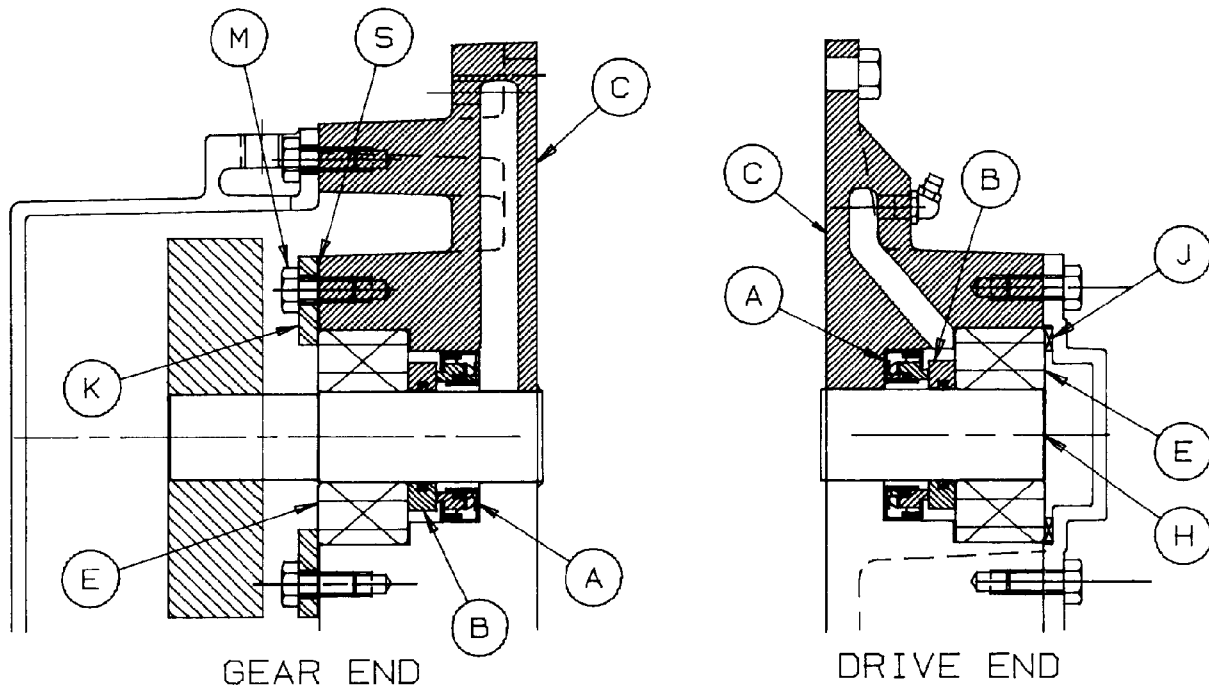

FIGURE 18

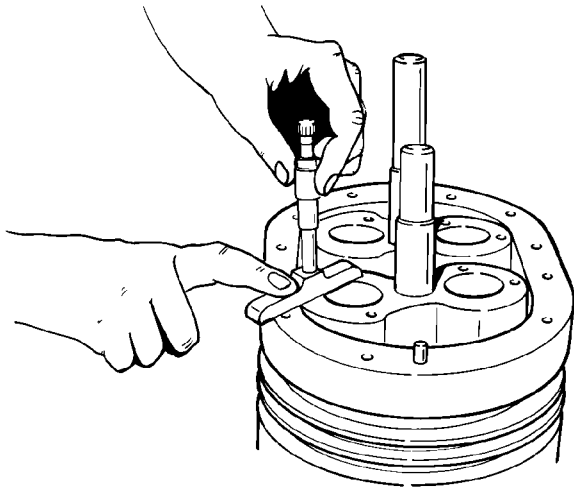

FIGURE 19

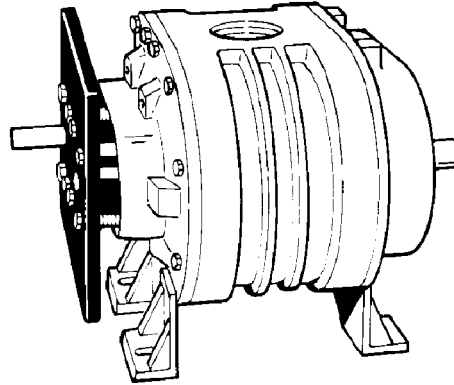

FIGURE 20

3. Assemble gear headplate (18) and mounting foot (17) to the impeller case with cap screws (21) and where the mounting foot is secured to the headplate use capscrews (16). The two positioning dowel pins (19) will ensure proper alignment of the headplate and impeller case. Also secure lifting lugs using capscrews (21) (see exploded assembly drawing page 25). Torque capscrews alternately and evenly. Refer to FIGURE 25, page 24, for torque specifications.
4. Apply a light oil or grease on the shaft seal areas and the bearing areas. Insert impellers into the gear headplate using the same headplate bores as used in the original assembly.



### CAUTION

**Seals are delicate; use extreme care when installing impeller shafts in the headplate bores. A piece of light shim stock wrapped around the shaft keyway will prevent cutting the seal lip.**

5. Position blower so that impellers are vertical, with the drive end on top. It will be necessary to use blocks in order for the unit to set level. Measure the total end clearance using a depth micrometer (see FIGURE 19).

If total clearance is not within the limits specified in FIGURE 21, page 20, it may be necessary to shim the case to obtain the proper total end clearance. The shim should be placed between the drive headplate and impeller case.

### NOTICE

**If more than .007" shim is required, put .007" on the drive end and the remaining on the gear end.**

6. Assemble drive headplate (24) to impeller case as done in step 3 with the gear headplate. If shims were required, place shims between drive headplate and impeller case.

### MECHANICAL SEALS ONLY

- A. Refer to FIGURE 18, page 18. Lightly coat the impeller shaft (H) and the inside diameter of the mating ring (B) with assembly lubricant.
- B. Install the mating ring (B) on the shaft only far enough to get the bearing (E) started on the shaft.
- C. Lightly lubricate the bearing inner race (E) with a light oil or grease.



### CAUTION

**Do not drive the mating ring down to the mechanical seal, as this can damage the seal.**

- D. Using a press, install the bearing on the shaft with the bearing driver shown on page 14.

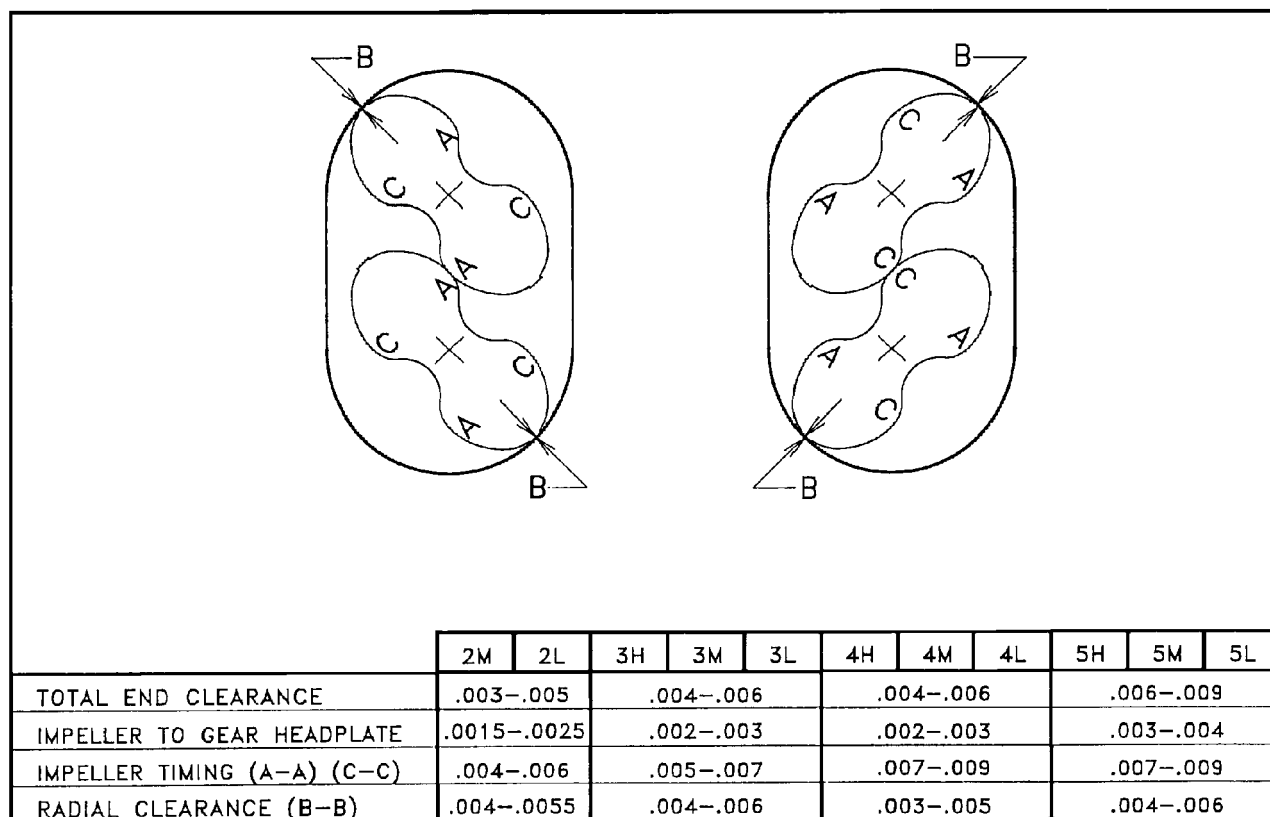

FIGURE 21

The bearing driver will position the mating ring (B) to the correct depth with respect to the mechanical seal (A).

7. Apply a light oil to the drive headplate bearing bore, bearing inside diameter, and shaft seat. Install the drive end bearings (14) as far as possible without force.
8. Attach the puller plate shown on page 13 to the drive headplate using the tapped holes used to secure the drive cover (see FIGURE 20, page 19). Tighten the bolts so that the advance of the bearings stay as uniform as possible. Bearings should be pressed until flush with the drive headplate.
9. Lubricate the gear end bearing fits with a light oil as described previously. Install gear end bearings (14) as far as possible without force. Use the plate, used to install the drive end bearings, to press the bearings on the shafts as described in Step 8. Press bearings into the gear headplate until completely seated in the bearing bore.

## NOTICE

**Bearings will not be flush with gear headplate bores when completely seated.**

10. Impellers should now be checked for free axial movement by hitting the ends of the impeller shafts with the palm of your hand.
11. Push the impellers against the gear headplate and recheck the total end clearance between the drive headplate and the impellers (see FIGURE 21).
  - A. If total end clearance is insufficient, loosen impeller case to headplate bolts on either headplate, and move the headplate away from the case far enough to insert a paper shim in the amount equal to the insufficient clearance. Retighten case bolts and again check the total end clearance. Refer to FIGURE 21 for correct clearance.
  - B. Excessive end clearances normally will require new impeller assemblies, but in some

circumstances the impeller case can be removed and reduced in width by machining off the amount of excess clearance.

**CAUTION**

These impeller-to-impeller and impeller-to-case clearances are extremely critical. Even though the blower may turn freely by hand when cold, under operating conditions, the parts expand, and the rotors are subject to slight deflection.

If the clearances are not sufficient, the impellers may contact each other or the housing with destructive results. If the clearances are too great, the blower may not develop the pressure or airflow that is required to perform its function.

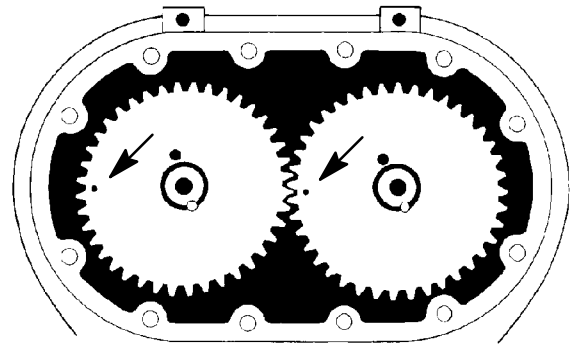

FIGURE 22

**CAUTION**

If installing gears on a blower containing mechanical seals, a press must be used to drive the gears on the shafts. Blows from a hammer or mallet will damage the seal.

12. Impeller tip to case clearance should be checked at this time by inserting the correct thickness feeler gauge between the tip and the case and rotating the impeller (see FIGURE 21, page 20). Repeat the procedure on both impellers.

**NOTICE**

When checking the tip to case clearance, move the feeler gauge over the entire length of the impeller to ensure that the tips do not bind along their length.

- C. Secure the bearing retainer plate (12) to the gear headplate using capscrews (10). Refer to FIGURE 25, page 24, for torque specifications.
- D. If reusing the timing gears, the gears should be returned to their original positions. Use taper pin holes and matchmarks for correct positioning.

**NOTICE**

Replacement gears have minimum backlash marks on the outside diameter of the gear face. These marks should be located 180 degrees from each other (see FIGURE 22).

13. INSTALLING THE TIMING GEARS

- A. Apply a light grease, or oil, on the shaft area where the timing gear will be positioned.
- B. Place feeler stock in the amount of 1/3 of the total end clearance between drive headplate and both impellers. This will stop the impellers from contacting the headplate while the gears are being driven on.

- E. Using the driving tool shown on page 13, drive one gear flush with the end of the shaft and replace taper pin (8) by rereaming original hole if the movement between the shaft and gear was negligible. If rereaming fails to eliminate edges set up by retiming, drill and ream a new hole approximately 90° from the

original hole. Control the depth of the taper pin, leaving approximately 1/8 in. taper pin protruding beyond the gear and end of shaft.

### NOTICE

**If gears are being replaced, taper pin holes must be drilled after the gears are correctly positioned.**



### CAUTION

**Be careful not to let cuttings drop behind the gears and contaminate the bearings.**

- F. Place impellers in the position shown in FIGURE 21, page 20. Check to be sure impellers are in correct position as previously match marked.
- G. Drive the mating gear on the other shaft within 1/2" of being flush with the end of the shaft.
- H. Refer to diagram in FIGURE 21, page 20. Use feeler gauges to check clearances between impeller lobes at positions A-A and C-C. Add the clearances, and divide the total clearance evenly between A-A and C-C.
- I. If the lobe clearance is not equal between A-A and C-C, the impellers require shifting relative to the gears. Insert a feeler gauge .010 inch larger than required clearance between the impellers at the tight spot and rotate the impellers wedging the feeler gauge between the lobes. Place the driving tool against the gear that is not flush with the end of the shaft, and strike the driver with a quick blow. This will drive the gear further onto the shaft, causing it to turn relative to the shaft due to the torque value set-up by the oversized feeler gauge wedged between the impeller lobes. Adjust so that the clearance at A-A is equal to C-C within .001 inch. Clearances must be checked on both sides of each impeller lobe over the entire length. This procedure may require repeating several times until the impeller lobe clearance is equal on both sides.

### NOTICE

**The gear used for adjustment should be flush with its mate on completion of the timing.**

- J. Check gear backlash four places at 90 degree intervals as described in the disassembly procedure (Item 4).

### NOTICE

**If any of the four gear backlash readings are not within the specified limits, the gears must be replaced.**

- 14. After timing adjustments are completed, insert taper pin between the shaft and adjustment gear by rereaming original hole if movement between the shaft and gear was negligible. If reaming fails to eliminate the edges due to slight misalignment, drill and ream a new hole approximately 90° from the original hole.

### NOTICE

**Replacement gears are not drilled. These holes must be drilled after the gears are in the proper position and the unit retimed.**

#### 15. SETTING IMPELLER END CLEARANCES

Refer to FIGURE 23, page 23. The outer races of the gear end bearings are clamped against the headplate (F) by the bearing retainer (B).

This is referred to as the "fixed end". The interference fit between the shaft and the bearing inner race (H) keeps the shaft from moving axially. Adjustment is by movement of the shaft through the gear end bearing inner race (H).

- A. Check the total end clearance by adding the clearance between the impellers and the drive headplate to the clearance between the impellers and the gear headplate.

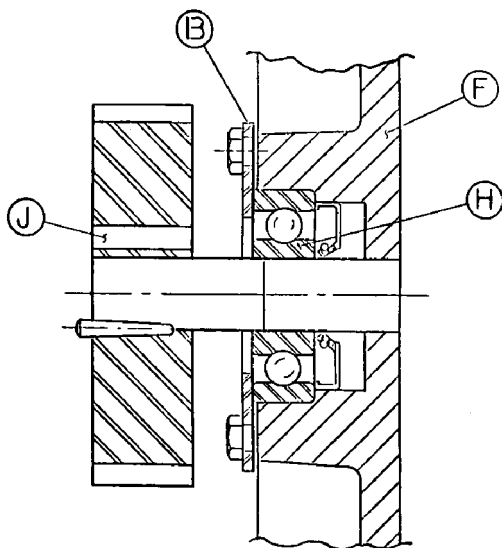

FIGURE 23

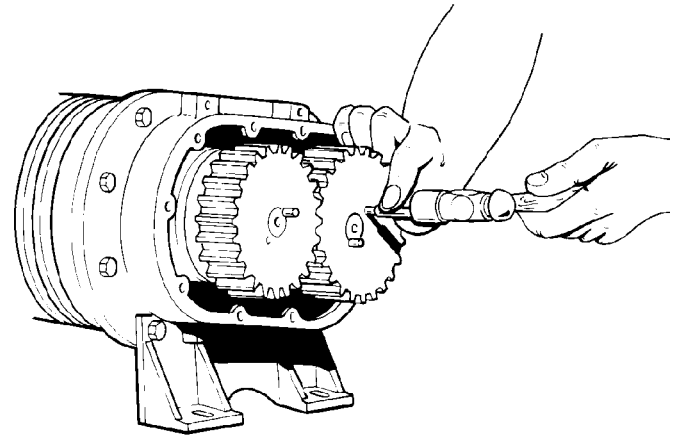

FIGURE 24

## NOTICE

**Check the clearance over the entire width of the impeller and consider the tightest spot.**

- B. Divide the total end clearance by 3 and distribute approximately 1/3 on the gear end and the remaining 2/3 on the drive end.
- C. To move the impeller assembly toward the drive end, lightly tap the shaft at the gear end with a soft face mallet.
- D. To set the fixed end, insert the feeler gauge in the amount specified in FIGURE 21, page 20, between the headplate and the impeller at the gear end.
- E. Insert a mild steel or soft metal rod thru the small hole in the gear (9). Tap lightly until the feeler gauge is snug. Adjust both impellers using the same procedure. Rotate the impellers checking for clearance through a complete revolution (see FIGURE 24).

### SETTING IMPELLER END CLEARANCE WITH MECHANICAL SEALS

Refer to FIGURE 18, page 18. The gear end bearings are held in position by the force created by the wavy spring (J) on the drive end and the bearing retainer (K)

on the gear end. This is referred to as the fixed end. The interference fit between the shaft (H) and the bearing inner race (E) keeps the shaft from moving axially.

End clearance adjustment is by movement of the bearing retainer (K). Tightening the bearing retainer screws (M) moves the bearing to load the wavy spring (J), and the impeller is forced toward the drive end. Relaxing the screws allows the wavy spring to return the impeller toward the gear end.

- A. Assemble drive cover to drive headplate. Refer to Step 16 with the exception of the use of wavy springs (J) installed between the drive end bearings and the drive cover.
- B. Back out retainer screws (M) until both impellers are tight against the gear headplate.
- C. With feeler gauge, measure the clearance between each impeller and the drive headplate. This value is the total end clearance.
- D. Measure the clearance between the gear headplate and bearing retainer (K) at point (S).
- E. Subtract 1/3 of the total end clearance from the clearance measured at point (S). This value is the amount of shim (13) that should be placed between the retainer and the headplate at point (S).
- F. Tighten the bearing retainer screws (M) to the torque value given in FIGURE 25, page 24. With the retainer screws secure, approximately 1/3 of the total end clearance should be on the gear end and the remaining 2/3 on the drive end.

16. Replace drive shaft grease seal (31) in the drive end cover (29). The seal lip should always face towards the bearing or lubricant. Pack bearing cavities with recommended grease and secure drive cover with capscrews (30) to drive headplate. Refer to FIGURE 25 for torque specifications.

 <b>CAUTION</b>
<b>Exercise care not to damage the seal lip as it passes over the shaft keyway.</b>

17. Assemble the gear cover (3) and gasket (7) to the gear headplate (18) using capscrews (5). Tighten

the capscrews alternately and evenly. Refer to FIGURE 25 for torque specifications.

18. Place the blower on its feet on a flat surface. Loosen cap screws (16) and level the unit up. The bench or blower base flatness should be within .002 of an inch. Re-tighten cap screws (16) to the specification in FIGURE 25.

<b>NOTICE</b>
<b>If the unit is not flat within .002 of an inch, it will be necessary to shim the blower feet at installation.</b>

FASTENERS	GEAR DIAMETER			
	2	3	4	5
CAPSCREW (21)	13 - 17	23 - 30	23 - 30	23 - 30
CAPSCREW (16)	13 - 17	23 - 30	23 - 30	23 - 30
SOCKET HD CAPSCREW (5)	6 - 8	6 - 8	13 - 17	13 - 17
SOCKET HD CAPSCREW (30)	6 - 8	6 - 8	13 - 17	6 - 8
CAPSCREW (10)	6 - 8	6 - 8	13 - 17	13 - 17

NOTE: ( ) DENOTES ITEMS IN EXPLODED VIEW DRAWINGS ON PAGES 25, 27, 29, AND 31.

FIGURE 25 - TORQUE (FT-LBS)



# SECTION 8 PARTS LIST

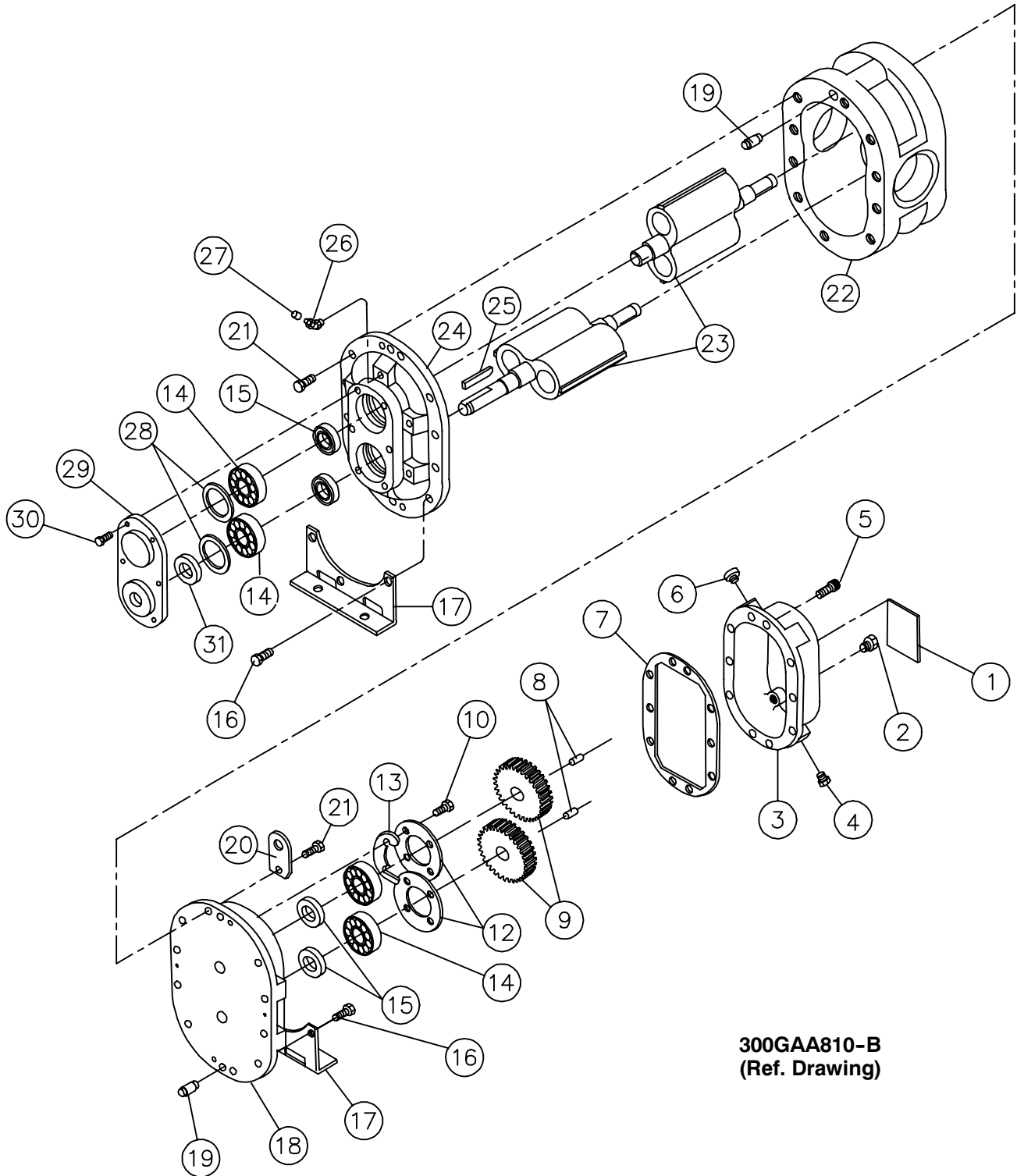

**300GAA810-B  
(Ref. Drawing)**

**Order by Part Number and Description. Reference Numbers are for your convenience only.**

**MODEL GAA**

Ref. No.	Description	No. Req'd	Size - 2M GAAM_P_	Size - 2L GAAL_P_
1	NAMEPLATE .....	1	302GAA496	302GAA496
2	OIL LEVEL PLUG... ..	2	64AC1	64AC1
3	GEAR CASE .....	1	900893022801	900893022801
4	DRAIN PLUG .....	1	64AC1	64AC1
5	SCREW-GEAR CASE TO BEARING HOUSING .....	6	75LM224	75LM224
6	VENT PLUG .....	1	900639650102	900639650102
o 7	GASKET GEAR CASE .....	1	200GAA715	200GAA715
o 8	TAPER PIN .....	2	62V73	62V73
9	TIMING GEAR GROUP .....	1	200GAA6008	200GAA6008
o 10	SCREW-BEARING RETAINER TO BEARING HOUSING .....	8	75A185N	75A185N
12	BEARING RETAINER. ....	2	900892021801	900892021801
+ 13	SHIM SET .....	1	900891022900	900891022900
o 14	BEARING. ....	4	12BA142	12BA142
o 15	MAIN SEAL-PER APPLICATION BELOW			
	LIP SEAL VERSION .....	4	60DD713	60DD713
	MECHANICAL SEAL VERSION .....	4	900871020002	900871020002
16	SCREW-FOOT TO BEARING HOUSING .....	6	75A34	75A34
17	FOOT GROUP			
	VERTICAL FOOT GROUP .....	1	GAA81896	GAA81896
	HORIZONTAL FOOT GROUP .....	1	GAA81897	GAA81897
18	HOUSING-BEARING (GEAR END)			
	LIP SEAL .....	1	900894021001	900894021001
	MECHANICAL SEAL .....	1	204GAA006	204GAA006
19	DOWEL PIN .....	4	62M48	62M48
20	LIFTING LUG.. ..	2	200GAA451	200GAA451
21	SCREW-BEARING HOUSINGS TO IMPELLER CASE .....	14	75A34	75A34
22	IMPELLER CASE. ....	1	900894021201	900894021401
23	SHAFT ASSEMBLY GROUP (SEAL VENTS) .....	1	GAA81899	GAA81898
	SHAFT ASSEMBLY GROUP CONSISTS OF:			
	(1) ASSEMBLY SHAFT - LONG			
	(1) ASSEMBLY SHAFT - SHORT			
24	HOUSING-BEARING (DRIVE)			
	LIP SEAL .....	1	900894020801	900894020801
	MECHANICAL SEAL .....	1	205GAA006	205GAA006
25	DRIVE KEY .....	1	900891023101	900891023101
26	GREASE FITTING .....	2	900639910304	900639910304
27	GREASE FITTING CAP .....	2	40P58	40P58
+ 28	WAVY SPRING .....	2	78W65	78W65
29	DRIVE COVER .....	1	900893021701	900893021701
30	SCREW-DRIVE COVER TO BEARING HOUSING .....	6	75A185N	75A185N
o 31	DRIVE SEAL .....	1	900639010802	900639010802
*+ 42	PLUGS REQUIRED WITH MECHANICAL SEAL .....	6	64AC1	64AC1
	SHIM-IMPELLER CASE			
	PAPER (.0015/.0020) .....	0	202GAA732	202GAA732
	PAPER (.003) .....	0	200GAA732	200GAA732
	ALUMINUM (.010) .....	0	201GAA732	201GAA732
o	OVERHAUL KIT LIP SEAL .....	0	200GAA6010	200GAA6010
o	OVERHAUL KIT MECHANICAL SEAL .....	0	201GAA6010	201GAA6010

\* NOT SHOWN

o OVERHAUL KITS CONSIST OF BEARINGS, SEALS, GASKET, SHIMS, TAPER PINS AND BEARING RETAINER SCREWS.

+ MECHANICAL SEAL UNITS ONLY.

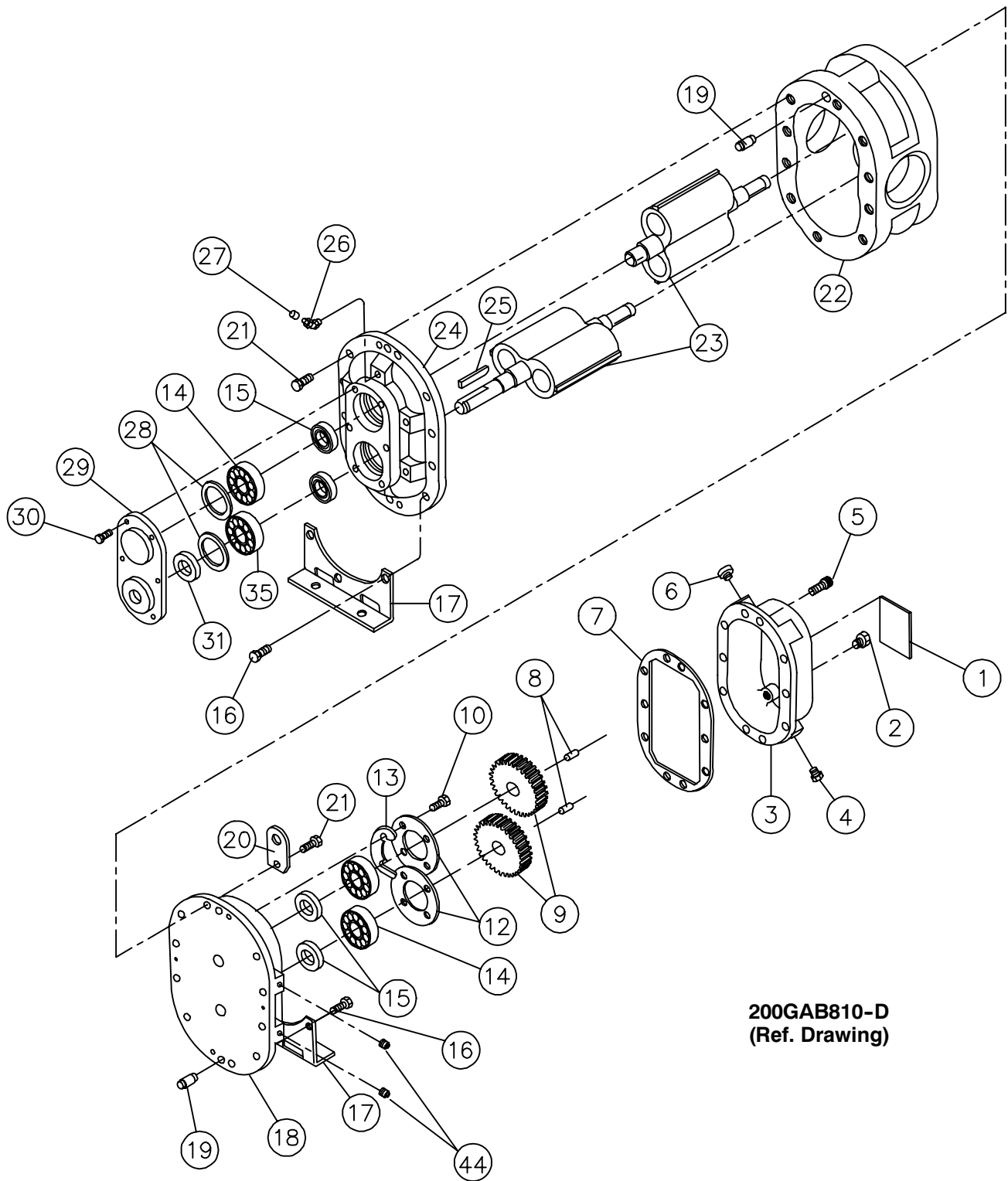

**200GAB810-D**  
**(Ref. Drawing)**

**Order by Part Number and Description. Reference Numbers are for your convenience only.**

Ref. No.	Description	No. Req'd	MODEL GAB		
			Size - 3H GABH_P_	Size - 3M GABM_P_	Size - 3L GABL_P_
1	NAMEPLATE .....	1	302GAA496	302GAA496	302GAA496
2	OIL LEVEL PLUG. ....	2	64AC2	64AC2	64AC2
3	GEAR CASE .....	1	900873032901	900873032901	900873032901
4	DRAIN PLUG. ....	1	64AC2	64AC2	64AC2
5	SCREW-GEAR CASE TO BEARING HOUSING .....	10	75LM224	75LM224	75LM224
6	BREATHER. ....	1	5L306	5L306	5L306
o 7	GASKET GEAR CASE .....	1	200GAB715	200GAB715	200GAB715
o 8	TAPER PIN .....	2	62V58	62V58	62V58
9	TIMING GEAR GROUP .....	1	201GAB6008	201GAB6008	201GAB6008
o 10	SCREW-BEARING RETAINER TO BEARING HOUSING ...	8	75A185N	75A185N	75A185N
12	BEARING RETAINER .....	2	900883031401	900883031401	900883031401
+ 13	SHIM SET .....	1	900881032200	900881032200	900881032200
o 14	BEARING. ....	3	12BA143	12BA143	12BA143
o 15	MAIN SEAL-PER APPLICATION BELOW				
	LIP SEAL VERSION .....	4	900891030601	900891030601	900891030601
	MECHANICAL SEAL VERSION .....	4	900871020003	900871020003	900871020003
16	SCREW-FOOT TO BEARING HOUSING .....	8	655ED050	655ED050	655ED050
17	FOOT GROUP				
	VERTICAL FOOT GROUP .....	1	GAB81903	GAB81903	GAB81903
	HORIZONTAL FOOT GROUP .....	1	GAB81904	GAB81904	GAB81904
18	HOUSING-BEARING (GEAR END)				
	LIP SEAL .....	1	900873033301	900873033301	900873033301
	MECHANICAL SEAL .....	1	900883030101	900883030101	900883030101
19	DOWEL PIN .....	4	62M48	62M48	62M48
20	LIFTING LUG .....	2	200GAA451	200GAA451	200GAA451
21	SCREW-BEARING HOUSINGS TO IMPELLER CASE .....	16	655ED040	655ED040	655ED040
22	IMPELLER CASE .....	1	900873034301	900873033801	900873034201
23	SHAFT ASSEMBLY GROUP .....	1	GAB81905	GAB81907	GAB81906
	SHAFT ASSEMBLY GROUP CONSISTS OF:				
	(1) ASSEMBLY SHAFT - LONG				
	(1) ASSEMBLY SHAFT - SHORT				
24	HOUSING-BEARING (DRIVE END)				
	LIP SEAL .....	1	900873033501	900873033501	900873033501
	MECHANICAL SEAL .....	1	900883030301	900883030301	900883030301
25	DRIVE KEY .....	1	900639910304	900639910304	900639910304
26	GREASE FITTING .....	2	40E9	40E9	40E9
27	GREASE FITTING CAP .....	2	40P58	40P58	40P58
+ 28	WAVY SPRING .....	2	900669170203	900669170203	900669170203
29	DRIVE COVER .....	1	900873033701	900873033701	900873033701
30	SCREW-DRIVE COVER TO BEARING HOUSING .....	6	75LM224	75LM224	75LM224
o 31	DRIVE SEAL .....	1	60DD725	60DD725	60DD725
o 35	BEARING DRIVE END DRIVE SHAFT .....	1	12BA153	12BA153	12BA153
*+ 42	PLUGS REQUIRED WITH MECHANICAL SEAL (Drive End)	4	64AC1	64AC1	64AC1
44	SCREW-SET .....	2	76F92	76F92	76F92
*+ 46	PLUGS REQUIRED WITH MECHANICAL SEAL (Gear End)	2	64AC2	64AC2	64AC2
	SHIM-IMPELLER CASE				
	PAPER (.0015/.0020) .....	0	202GAB732	202GAB732	202GAB732
	PAPER (.003) .....	0	200GAB732	200GAB732	200GAB732
	ALUMINUM (.010) .....	0	201GAB732	201GAB732	201GAB732
o	OVERHAUL KIT LIP SEAL .....	0	203GAB6010	203GAB6010	203GAB6010
o	OVERHAUL KIT MECHANICAL SEAL .....	0	204GAB6010	204GAB6010	204GAB6010

\* NOT SHOWN

o OVERHAUL KITS CONSIST OF BEARINGS, SEALS, GASKET, SHIMS, TAPER PINS AND BEARING RETAINER SCREWS.

+ MECHANICAL SEAL UNITS ONLY.

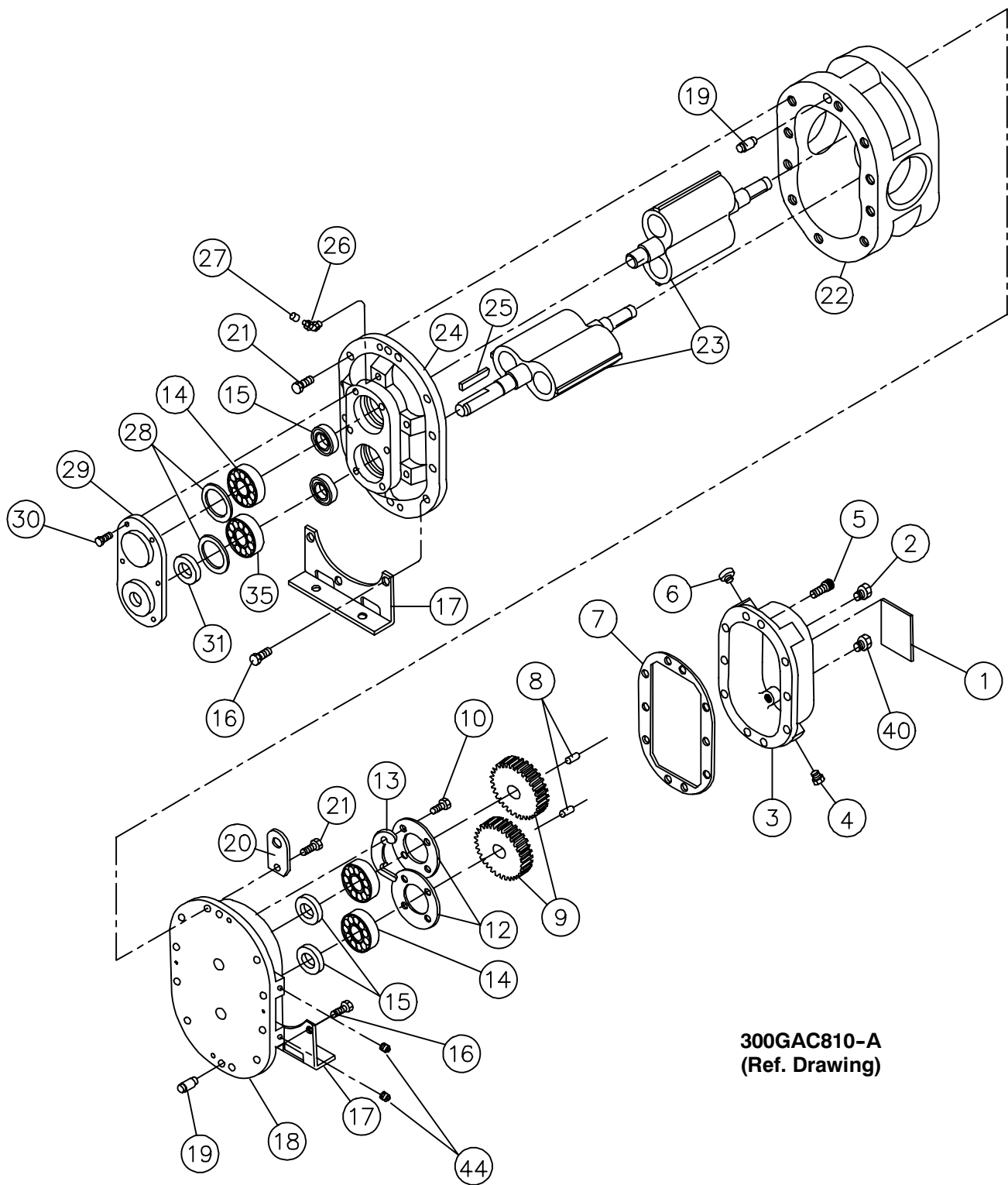

**300GAC810-A  
(Ref. Drawing)**

**Order by Part Number and Description. Reference Numbers are for your convenience only.**

Ref. No.	Description	No. Req'd	MODEL GAC		
			Size - 4H GACH_P_	Size - 4M GACM_P_	Size - 4L GACL_P_
1	NAMEPLATE .....	1	302GAA496	302GAA496	302GAA496
2	PLUG FOR ALTERNATE OIL LEVEL CONN. ....	1	64AC3	64AC3	64AC3
3	GEAR CASE .....	1	900883040701	900883040701	900883040701
4	DRAIN PLUG .....	1	64AC2	64AC2	64AC2
5	SCREW-GEAR CASE TO BEARING HOUSING .....	12	75LM113	75LM113	75LM113
6	BREATHER .....	1	5L306	5L306	5L306
o 7	GASKET GEAR CASE .....	1	200GAC715	200GAC715	200GAC715
o 8	TAPER PIN .....	2	62V58	62V58	62V58
9	TIMING GEAR GROUP .....	1	200GAC6008	200GAC6008	200GAC6008
o 10	SCREW-BEARING RETAINER TO BEARING HOUSING ...	8	75A33N	75A33N	75A33N
12	BEARING RETAINER .....	2	900883040201	900883040201	900883040201
+ 13	SHIM SET .....	1	900881042900	900881042900	900881042900
o 14	BEARING .....	3	12BA144	12BA144	12BA144
o 15	MAIN SEAL-PER APPLICATION BELOW				
	LIP SEAL VERSION .....	4	60DD630	60DD630	60DD630
	MECHANICAL SEAL VERSION .....	4	900871020004	900871020004	900871020004
16	SCREW-FOOT TO BEARING HOUSING .....	8	655ED050	655ED050	655ED050
17	FOOT GROUP				
	VERTICAL FOOT GROUP .....	1	GAC81911	GAC81911	GAC81911
	HORIZONTAL FOOT GROUP .....	1	GAC81912	GAC81912	GAC81912
18	HOUSING-BEARING (GEAR END)				
	LIP SEAL .....	1	900883040501	900883040501	900883040501
	MECHANICAL SEAL .....	1	900883041601	900883041601	900883041601
19	DOWEL PIN .....	4	62M48	62M48	62M48
20	LIFTING LUG. ....	2	200GAA451	200GAA451	200GAA451
21	SCREW-BEARING HOUSINGS TO IMPELLER CASE .....	16	655ED040	655ED040	655ED040
22	IMPELLER CASE .....	1	900883042201	900883041801	900883042001
23	SHAFT ASSEMBLY GROUP .....	1	208GAC4028	207GAC4028	206GAC4028
	SHAFT ASSEMBLY GROUP CONSISTS OF:				
	(1) ASSEMBLY SHAFT - LONG				
	(1) ASSEMBLY SHAFT - SHORT				
24	HOUSING-BEARING (DRIVE END)				
	LIP SEAL .....	1	300GAC006	300GAC006	300GAC006
	MECHANICAL SEAL .....	1	900883041201	900883041201	900883041201
25	DRIVE KEY .....	1	900639910304	900639910304	900639910304
26	GREASE FITTING .....	2	40E9	40E9	40E9
27	GREASE FITTING CAP .....	2	40P58	40P58	40P58
+ 28	WAVY SPRING. ....	2	900669170304	900669170304	900669170304
29	DRIVE COVER .....	1	900883040301	900883040301	900883040301
30	SCREW-DRIVE COVER TO BEARING HOUSING .....	8	75LM113	75LM113	75LM113
o 31	DRIVE SEAL. ....	1	60DD716	60DD716	60DD716
o 35	BEARING-ROLLER .....	1	12BA154	12BA154	12BA154
40	GAUGE-OIL LEVEL .....	1	40P34	40P34	40P34
*+ 42	PLUGS REQUIRED WITH MECHANICAL SEAL (Drive End)	4	64AC1	64AC1	64AC1
44	SCREW-SET .....	2	76F92	76F92	76F92
*+ 46	PLUGS REQUIRED WITH MECHANICAL SEAL (Gear End) .	2	64AC2	64AC2	64AC2
	SHIM-IMPELLER CASE				
	PAPER (.0015/.0020) .....	0	202GAC732	202GAC732	202GAC732
	PAPER (.003) .....	0	200GAC732	200GAC732	200GAC732
	ALUMINUM (.010) .....	0	201GAC732	201GAC732	201GAC732
o	OVERHAUL KIT LIP SEAL. ....	0	202GAC6010	202GAC6010	202GAC6010
o	OVERHAUL KIT MECHANICAL SEAL .....	0	203GAC6010	203GAC6010	203GAC6010

\* NOT SHOWN

o OVERHAUL KITS CONSIST OF BEARINGS, SEALS, GASKET, SHIMS, TAPER PINS AND BEARING RETAINER SCREWS.

+ MECHANICAL SEAL UNITS ONLY.

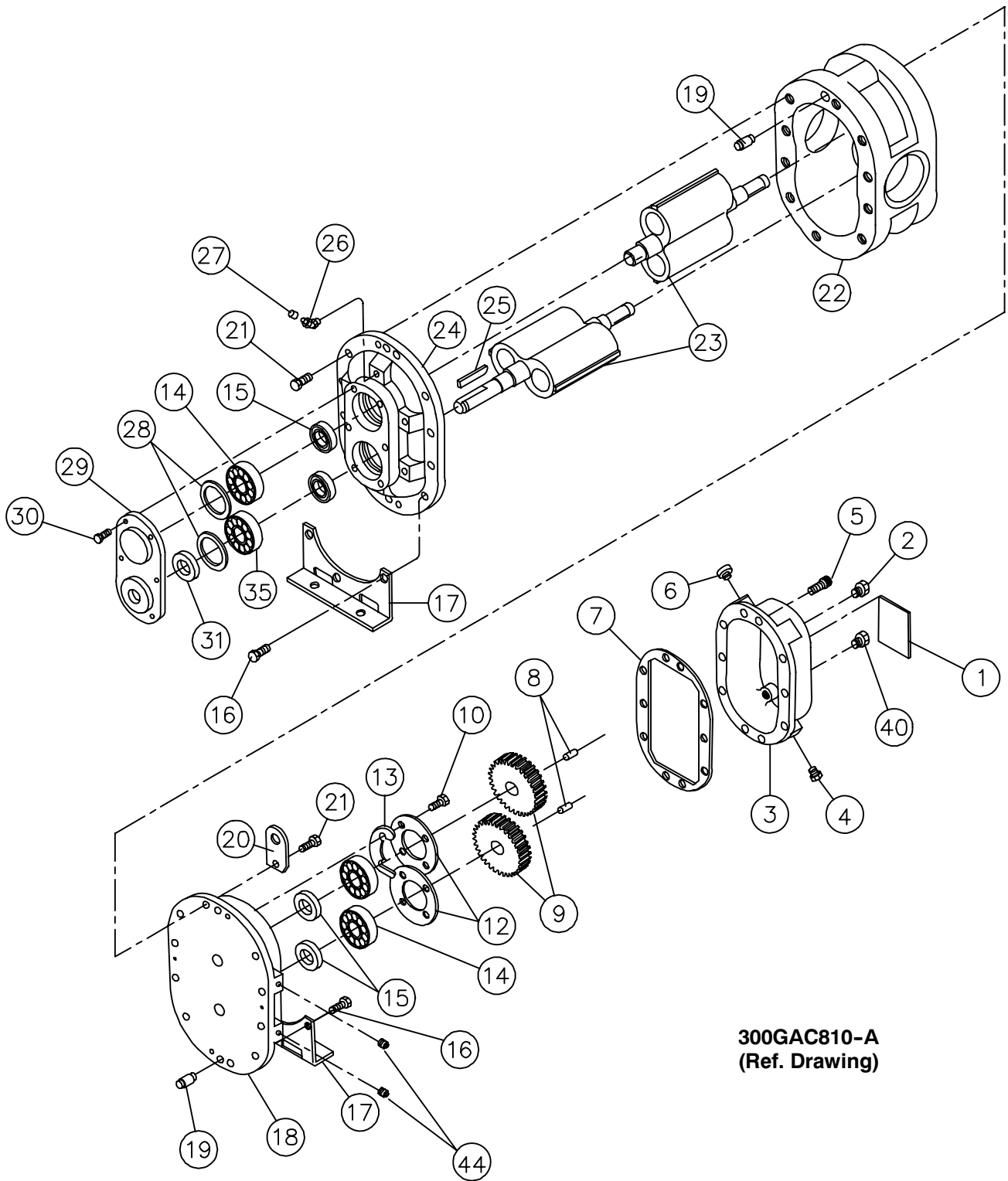

**300GAC810-A  
(Ref. Drawing)**

**Order by Part Number and Description. Reference Numbers are for your convenience only.**

Ref. No.	Description	No. Req'd	MODEL GAE		
			Size - 5H GAEH_P_	Size - 5M GAEM_P_	Size - 5L GAEL_P_
1	NAMEPLATE .....	1	301GAE496	301GAE496	301GAE496
2	PLUG FOR ALTERNATE OIL LEVEL CONN. ....	1	64AC3	64AC3	64AC3
3	GEAR CASE .....	1	900883051001	900883051001	900883051001
4	DRAIN PLUG .....	1	64AC2	64AC2	64AC2
5	SCREW-GEAR CASE TO BEARING HOUSING .....	12	75LM113	75LM113	75LM113
6	VENT PLUG .....	1	5L306	5L306	5L306
o 7	GASKET GEAR CASE .....	1	200GAE715	200GAE715	200GAE715
o 8	TAPER PIN .....	2	62V58	62V58	62V58
9	TIMING GEAR GROUP .....	1	201GAE6008	201GAE6008	201GAE6008
o 10	SCREW-BEARING RETAINER TO BEARING HOUSING ...	8	75A33N	75A33N	75A33N
12	BEARING RETAINER. ....	2	900883050501	900883050501	900883050501
+ 13	SHIM SET .....	1	900881052900	900881052900	900881052900
o 14	BEARING .....	3	8500397	8500397	8500397
o 15	MAIN SEAL-PER APPLICATION BELOW				
	LIP SEAL VERSION .....	4	60DD714	60DD714	60DD714
	MECHANICAL SEAL VERSION .....	4	900871020005	900871020005	900871020005
16	SCREW-FOOT TO BEARING HOUSING .....	8	655ED050	655ED050	655ED050
17	FOOT GROUP				
	VERTICAL FOOT GROUP .....	1	GAE81922	GAE81922	GAE81922
	HORIZONTAL FOOT GROUP .....	1	GAE81923	GAE81923	GAE81923
18	HOUSING-BEARING (GEAR END)				
	LIP SEAL .....	1	900883052101	900883052101	900883052101
	MECHANICAL SEAL .....	1	900883050301	900883050301	900883050301
19	DOWEL PIN. ....	4	62M48	62M48	62M48
20	LIFTING LUG .....	2	200GAA451	200GAA451	200GAA451
21	SCREW-BEARING HOUSINGS TO IMPELLER CASE .....	24	655ED040	655ED040	655ED040
22	IMPELLER CASE .....	1	900883051701	900883051801	900883051901
23	SHAFT ASSEMBLY GROUP .....	1	207GAE4028	206GAE4028	205GAE4028
	SHAFT ASSEMBLY GROUP CONSISTS OF:				
	(1) ASSEMBLY SHAFT - LONG				
	(1) ASSEMBLY SHAFT - SHORT				
24	HOUSING-BEARING (DRIVE END)				
	LIP SEAL .....	1	206GAE006	206GAE006	206GAE006
	MECHANICAL SEAL .....	1	207GAE006	207GAE006	207GAE006
25	DRIVE KEY .....	1	900639910305	900639910305	900639910305
26	GREASE FITTING .....	2	911659990606	911659990606	911659990606
27	GREASE FITTING CAP .....	2	40P58	40P58	40P58
+ 28	WAVY SPRING .....	2	900669170405	900669170405	900669170405
29	DRIVE COVER .....	1	900883050401	900883050401	900883050401
30	SCREW-DRIVE COVER TO BEARING HOUSING .....	8	75LM113	75LM113	75LM113
o 31	DRIVE SEAL .....	1	60DD726	60DD726	60DD726
o 35	BEARING-ROLLER .....	1	12BA155	12BA155	12BA155
40	GAUGE-OIL LEVEL .....	1	40P34	40P34	40P34
*+ 42	PLUGS REQUIRED WITH MECHANICAL SEAL (Drive End)	4	64AC1	64AC1	64AC1
44	SCREW-SET .....	4	76F92	76F92	76F92
*+ 46	PLUGS REQUIRED WITH MECHANICAL SEAL (Gear End) .	4	64AC2	64AC2	64AC2
	SHIM-IMPELLER CASE				
	PAPER (.0015/.0020) .....	0	202GAE732	202GAE732	202GAE732
	PAPER (.003) .....	0	200GAE732	200GAE732	200GAE732
	ALUMINUM (.010) .....	0	201GAE732	201GAE732	201GAE732
	OVERHAUL KIT LIP SEAL .....	0	200GAE6010	200GAE6010	200GAE6010
	OVERHAUL KIT MECHANICAL SEAL .....	0	203GAE6010	203GAE6010	203GAE6010

\* NOT SHOWN

o OVERHAUL KITS CONSIST OF BEARINGS, SEALS, GASKET, SHIMS, TAPER PINS AND BEARING RETAINER SCREWS.

+ MECHANICAL SEAL UNITS ONLY.



**SUTORBILT BLOWERS  
SUTORBILT LEGEND SERIES****GENERAL PROVISIONS AND LIMITATIONS**

Gardner Denver (the "Company") warrants to each original retail purchaser ("Purchaser") of its new products from the Company or its authorized distributor that such products are, at the time of delivery to the Purchaser, made with good material and workmanship. No warranty is made with respect to:

1. Any product which has been repaired or altered in such a way, in the Company's judgment, as to affect the product adversely.
2. Any product which has, in the Company's judgment been subject to negligence, accident, improper storage, or improper installation or application.
3. Any product which has not been operated or maintained in accordance with normal practice and with the recommendations of the Company.
4. Components or accessories manufactured, warranted and serviced by others.
5. Any reconditioned or prior owned product.

Claims for items described in (4) above should be submitted directly to the manufacturer.

**WARRANTY PERIOD**

The Company's obligation under this warranty is limited to repairing or, at its option, replacing, during normal business hours at an authorized service facility of the Company, any part which in its judgment proved not to be as warranted within the applicable Warranty Period as follows.

**BARE BLOWERS**

Basic bare blowers, consisting of all parts within, are warranted for 18 months from date of initial use or 24 months from date of shipment to the first purchaser, whichever occurs first.

Any disassembly or partial disassembly of the blower, or failure to return the "unopened" blower per Company instructions, will be cause for denial of warranty.

**OTHER COMPONENTS**

All other components are warranted for 12 months from date of initial use or 18 months from date of shipment to first purchaser, whichever comes first.

The Company reserves the right to withdraw the Warranty where evidence indicates application outside the stated performance area, or where there is evidence of abuse.

**LABOR TRANSPORTATION AND INSPECTION**

The Company will provide labor, by Company representative or authorized service personnel, for repair or replacement of any product or part thereof which in the

Company's judgment is proved not to be as warranted. Labor shall be limited to the amount specified in the Company's labor rate schedule.

Labor costs in excess of the Company rate schedule amounts or labor provided by unauthorized service personnel is not provided for by this warranty.

Transportation of Company's choice, within the continental United States, is covered by this warranty for replacement of any blower which in the Company's judgement proved not to be as warranted. For user locations outside the continental United States, the Company will provide transportation, by the carrier of its choice to and from the nearest Authorized Distributor and the Company's designated facility. The Company may require the return of any blower claimed not to be as warranted to one of its facilities as designated by the Company, transportation prepaid by Purchaser, to establish a claim under this warranty.

Replacement parts provided under the terms of the warranty are warranted for the remainder of the Warranty Period of the product upon which installed to the same extent as if such parts were original components thereof.

**DISCLAIMER**

THE FOREGOING WARRANTY IS EXCLUSIVE AND IT IS EXPRESSLY AGREED THAT, EXCEPT AS TO TITLE, THE COMPANY MAKES NO OTHER WARRANTIES, EXPRESSED, IMPLIED OR STATUTORY, INCLUDING ANY IMPLIED WARRANTY OF MERCHANTABILITY.

THE REMEDY PROVIDED UNDER THIS WARRANTY SHALL BE THE SOLE, EXCLUSIVE AND ONLY REMEDY AVAILABLE TO PURCHASER AND IN NO CASE SHALL THE COMPANY BE SUBJECT TO ANY OTHER OBLIGATIONS OR LIABILITIES. UNDER NO CIRCUMSTANCES SHALL THE COMPANY BE LIABLE FOR SPECIAL, INDIRECT, INCIDENTAL OR CONSEQUENTIAL DAMAGES, EXPENSES, LOSSES OR DELAYS HOWSOEVER CAUSED.

No statement, representation, agreement, or understanding, oral or written, made by any agent, distributor, representative, or employee of the Company which is not contained in this Warranty will be binding upon the Company unless made in writing and executed by an officer of the Company.

This warranty shall not be effective as to any claim which is not presented within 30 days after the date upon which the product is claimed not to have been as warranted. Any action for breach of this warranty must be commenced within one year after the date upon which the cause of action occurred.

Any adjustment made pursuant to this warranty shall not be construed as an admission by the Company that any product was not as warranted.

---

**Gardner**  
**Denver**

Specifications subject to change without notice  
© Copyright 2005 Gardner Denver, Inc. Litho in U.S.A.



Sunco Powder Systems, Inc.  
Blower Division  
Phone: (704) 545-3922  
[www.suncoblomers.com](http://www.suncoblomers.com)